

Podio X2

Operator Manual



Operator machine guidance website

Scan the QR code for all Operator machine guidance



Access includes:



Guides

- Replenishment
- Alarm guide
- Drink Preparation



Compliance

- MSDS & COSHH
- Daily compliance log*
- Health & Safety



Videos

- Drink preparation
- Machine overview
- Daily cleaning
- Descale
- Filter change

*Subject to in market set-up

Contents

Machine Overview	4
1.1 Closed machine navigation	5
1.2 Open machine navigation	6
1.3 Technical data	7
Operation	8
2.1 Heating up	9
2.2 Rinsing the circuits	9
2.3 Machine ready to use	9
2.4 Select product to dispense	10
2.5 When dispensing a product	11
2.7 When the drink is ready	12
2.7 When the drink is ready	12
2.8 Hot water dispense	12
2.9 Filter change (non-plumbed machines ONLY)	13
Dispensing a product	15
3.1 Drink offering overview	16
3.2 Cup height adjustment	17
3.3 Correct drink selection	18
3.4 Dispensing a drink	18
Cleaning	19
4.1 Items required for cleaning:	20
4.2 Cleaning the drink outlet:	21
4.3 Cleaning the removable areas:	21
4.4 Cleaning the external surfaces:	24
Descaling (non-plumbed machines ONLY)	25
5.1 Complete descale (non-plumbed machines ONLY):	26
5.2 Thermoblock descale (non-plumbed machines ONLY):	30

1.
Machine Overview

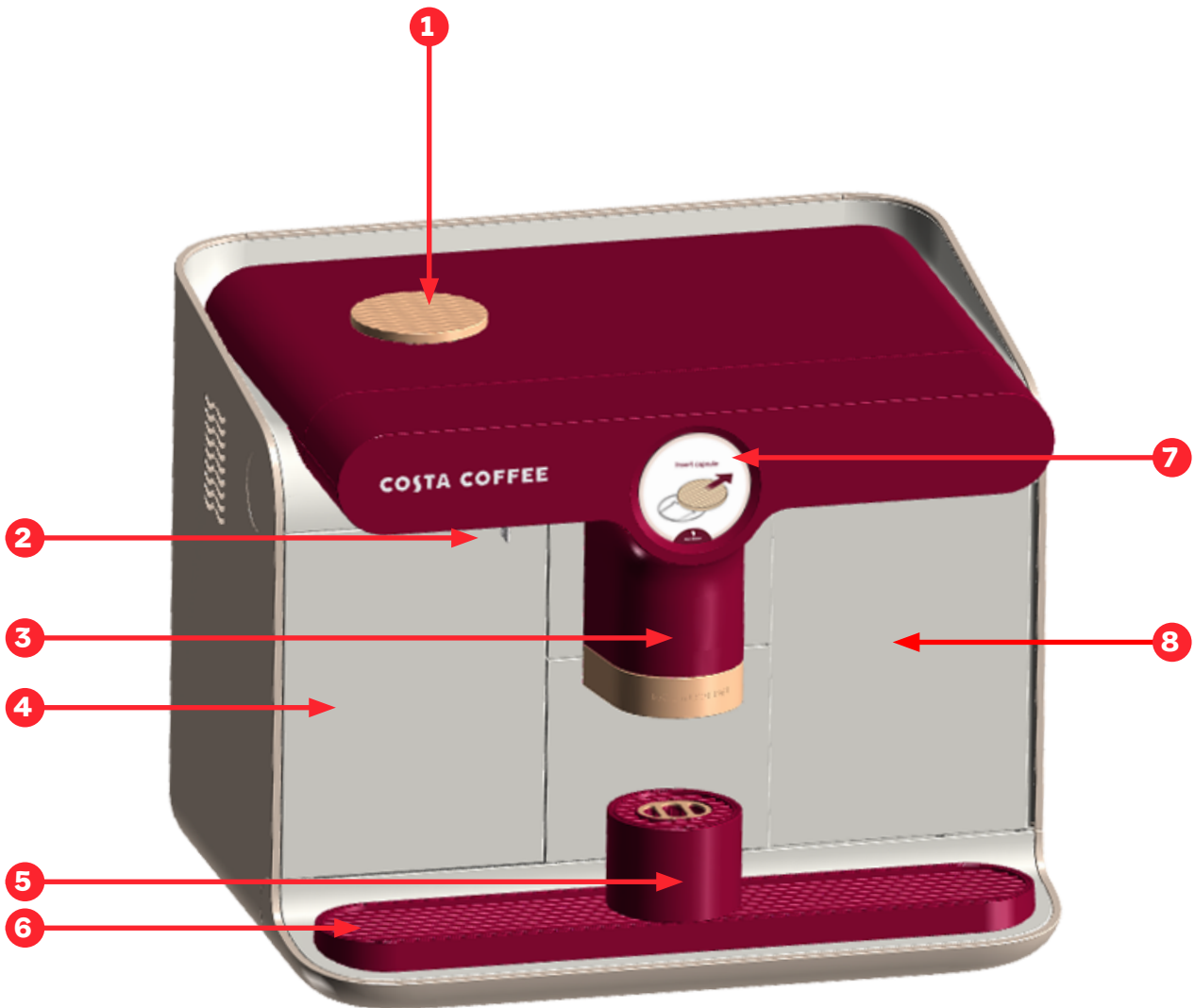

Glossary of Parts

- 1 Capsule insert & cover
- 2 Upper door key
- 3 Drink outlet
- 4 Left door (access to capsule drawer)
- 5 Espresso cup stand
- 6 Drip tray
- 7 Touch screen
- 8 Right door (Access to Water Tanks)

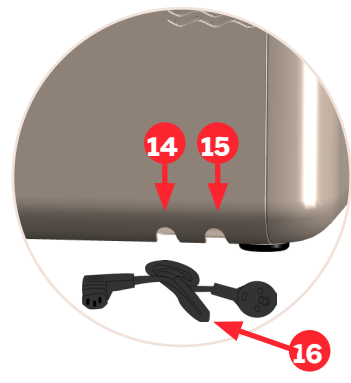
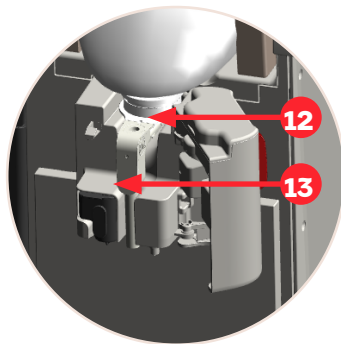
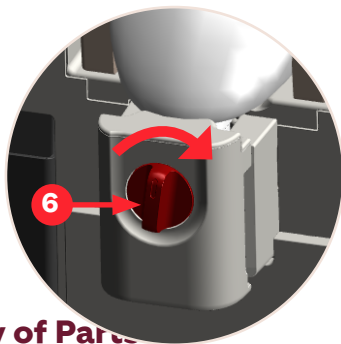
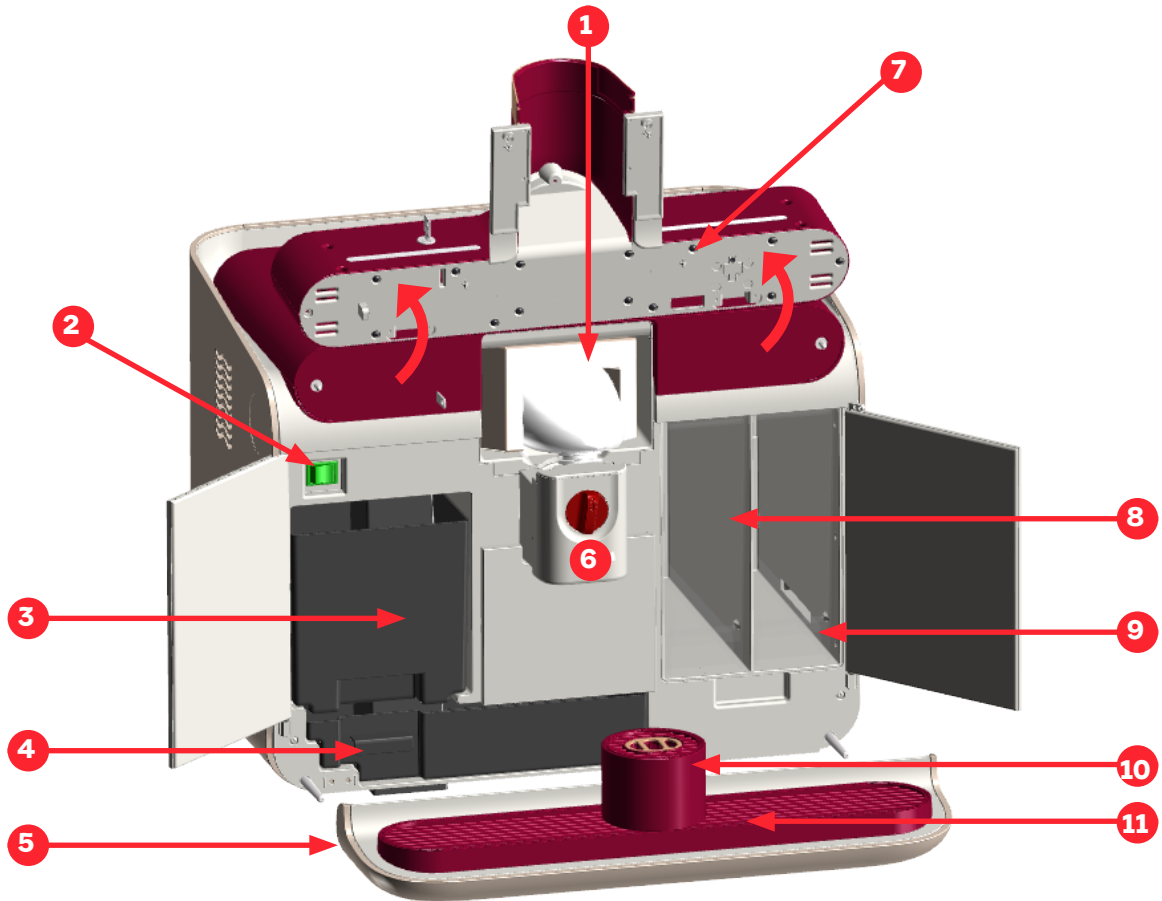

Glossary of Parts

- 1** Milk Product BiB
- 2** On/Off switch
- 3** Capsule drawer
- 4** Internal drip tray
- 5** Drip tray holder
- 6** Coffee nozzle/milk product drink outlet housing
- 7** Hood
- 8** Water container (coffee)
- 9** Milk module water container
- 10** Espresso cup stand
- 11** Drip tray
- 12** Milk product outlet
- 13** Coffee nozzle outlet
- 14** Water connection
(optional, right hand side on back of the machine)
- 15** Power cord socket
(right hand side on back of the machine)
- 16** Power cord
(right hand side on back of the machine)



Model	Podio X3
Dimensions H x W x D - (mm)	480 x 600 x 500
Weight (kg). (empty machine)	34 (38.5 when in box for shipping)
Max. Power Input (W)	See the technical data plate located inside the used capsule drawer.
Operating voltage (V)	See the technical data plate located inside the used capsule drawer.
Operating conditions	Temperature (Min. 10°C/50°F - Max. 40°C/104°F) Humidity (below 90%)
Water tank capacity	4 litres
Capsule drawer capacity	30
Pump pressure	Max. 2.0 MPa (20 bar)
Water supply pressure	See the technical data plate located inside the used capsule drawer.

The materials and objects in contact with food products comply with the requirements of European Regulation 1935/2004.

2.
Operation



When the machine is switched on, the following screens will display before it is ready for use.



Machine in heating up phase

BiB days of validity

The machine has been turned on and is heating up.

2.2 Rinsing the circuits

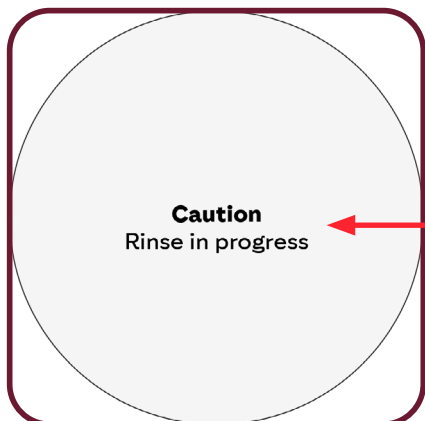

Rinse phase varies according to the machine status or use

After heating up, the machine performs a rinse cycle of all the circuits used for dispensing products. This screen is always shown when the machine is rinsing the internal circuits.

2.3 Machine ready to use

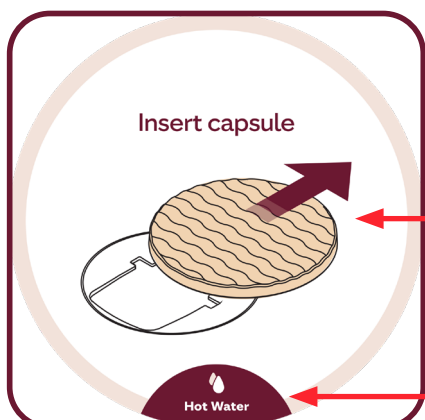

Machine is ready to use; insert capsule

Hot Water dispense only

The machine is hot and ready to be used; insert the desired capsule.

2.4 Select product to dispense

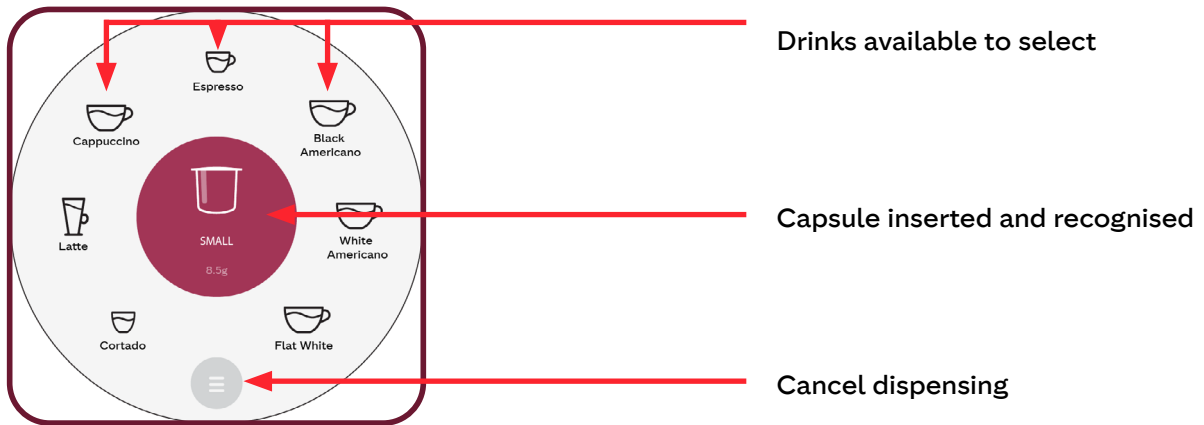

Once the capsule is inserted, the touch screen displays the drinks available based on the capsule type and size e.g. small/large.



Only drinks shown on the display can be selected.

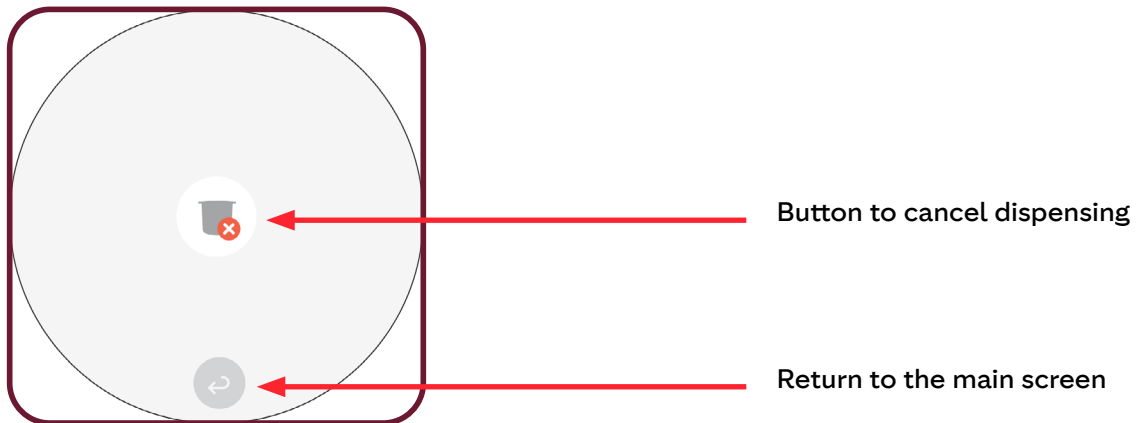

Drink selection can be cancelled by pressing the “Cancel dispensing” button. If the user wants to cancel dispensing, press the central button: the machine will disregard the inserted capsule without dispensing the product.

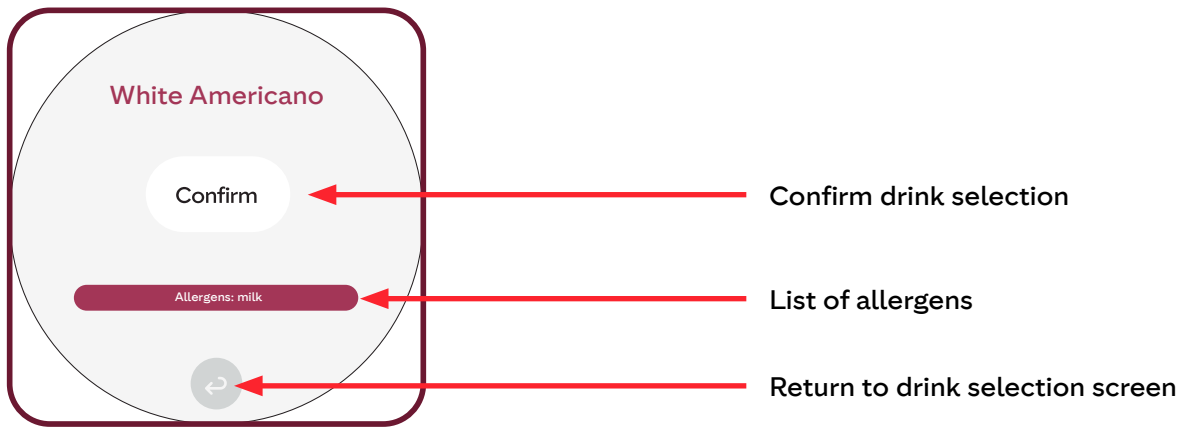

After selecting the product, confirm the selection or return to drink selection screen.



- **Before starting to dispense the product, check the list of allergens that are shown on the display and that will be present in the dispensed product; this is important to avoid substances that can cause allergic reaction.**
- **Allergen information displayed on the touch screen is correct as per the drink and ingredients the machine dispenses.**
- **Any additional ingredients added e.g. syrup will need to be managed at a local level and correct allergen information provided.**

2.5 When dispensing a product

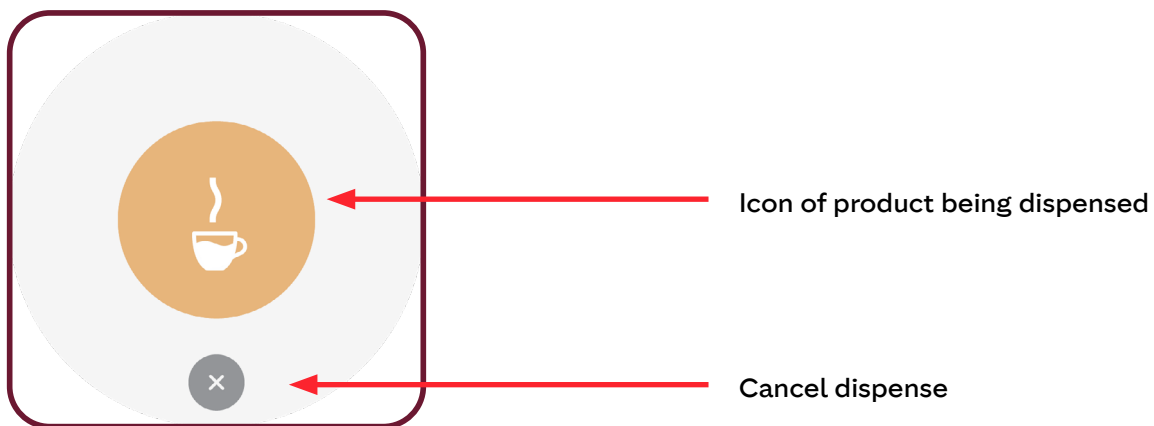

The icon of the selected product is shown during the entire preparation phase.

2.7 When the drink is ready



← Dispensing has been stopped by user

i

Dispensing is also terminated if a machine component is removed e.g. used capsule drawer.

2.7 When the drink is ready



When the machine has successfully finished preparing the drink the above icon will display on the screen.

2.8 Hot water dispense

i

When required, Podio can dispense hot water e.g. to make tea. Follow the below process:

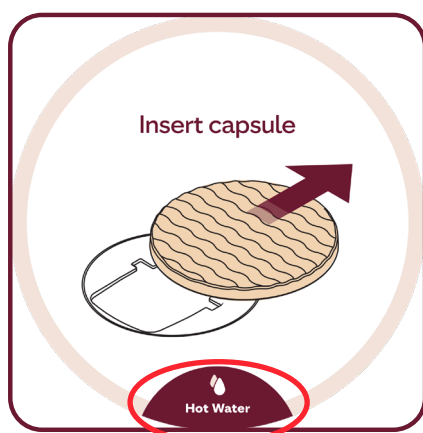

Press the "Hot Water" button.

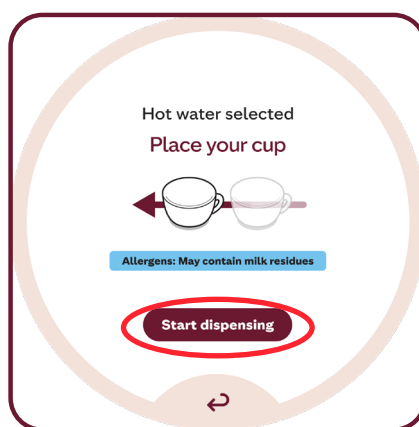

Place the cup and press "Start dispensing".



The machine dispense up to 175ml of hot water or stop when "Stop" is pressed.



The following is for **WATER TANK/NON-PLUMBED** machines that require a filter **ONLY**.

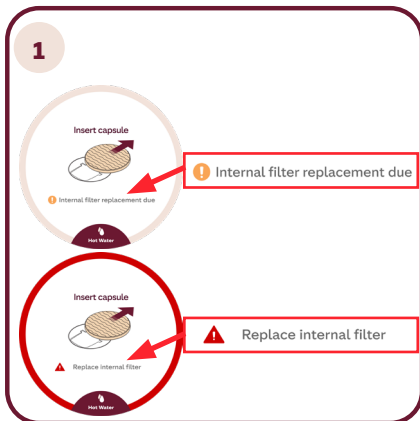

When the filter change is due/required the message will appear on the touch screen.



Rinse the **water tank** and place on a clean surface.



Unpack the **new filter** and check inlet holes are clearly visible.

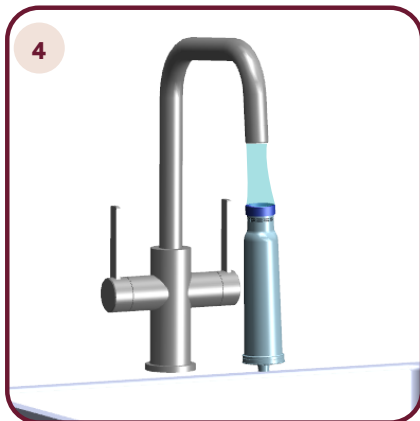

Hold the **new filter** under cold running water for approx. 60 seconds to prime the filter.

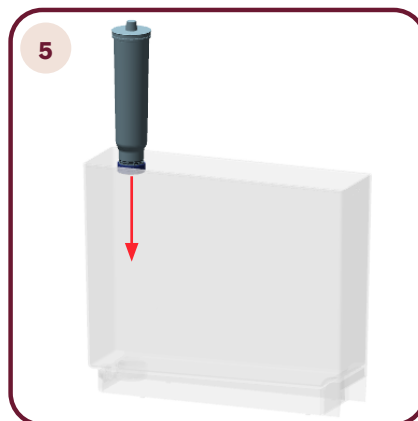

Insert the **filter** into the water tank.

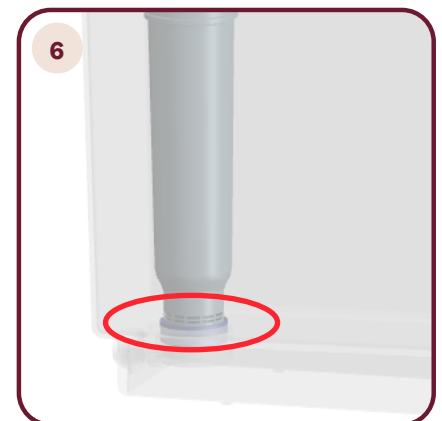

Check that the **inlet holes** are visible.



Refill the **water tank** with fresh water, return to the machine.

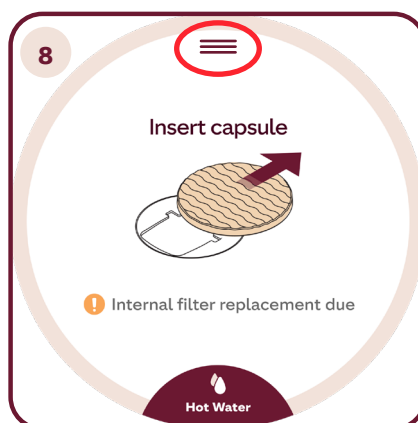

From the touch screen, press the **top button** to enter the operator menu.

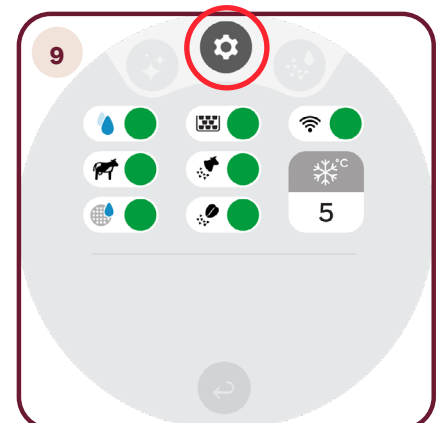

Enter "**Settings**".



Press **“Water filter change”**.

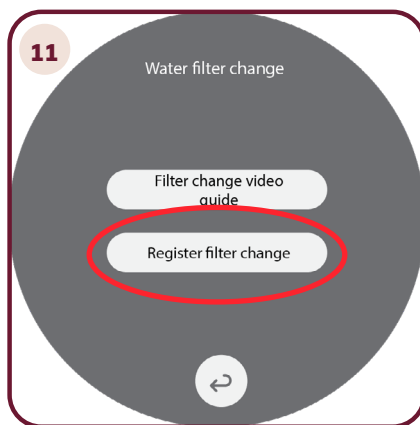

Press **“Register filter change”**.

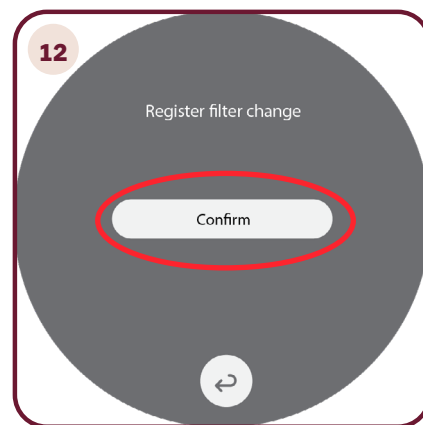

Press **“Confirm”**.

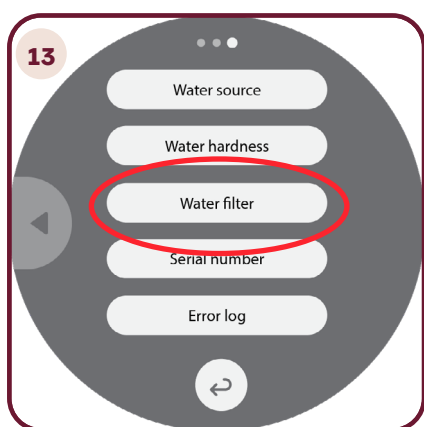

Navigate to page 3 and press **“Water filter”**.

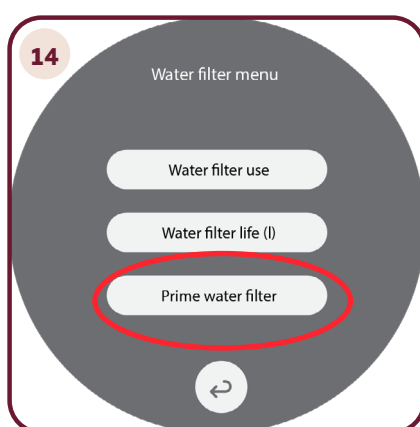

Press **“Prime water filter”**.

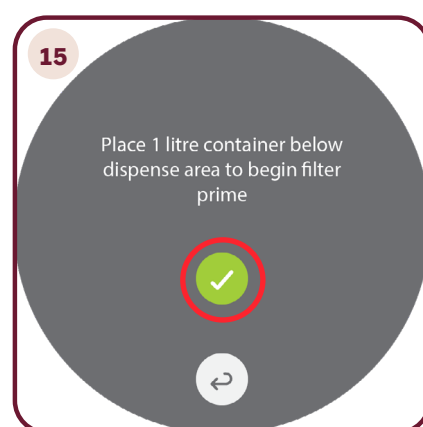

Place a **1 litre** container below dispense area to begin filter prime and press the tick. After priming, rinse container.

3.
Dispensing a product



i

Drink offerings and capsule availability vary by market and machine setup.

Step 1: Choose drink

Step 2: Choose blend

Small Espresso-based coffees:

- Espresso
- Espresso Macchiatto
- Ristretto
- White Americano/Black Americano
- Cappuccino
- Latte



Signature blend
Medium Roast | Smooth & Nutty
Intensity: **8**



Signature blend
Dark Roast | Bold & Chocolatey
Intensity: **10**



Columbian
Medium Roast | Rich & Caramelly
Intensity: **7**



Decaf blend
Medium Roast | Caramelly & Chocolatey
Intensity: **6** **8.5g**

Large Espresso-based coffees:

- Espresso
- Espresso Macchiatto
- Cortado
- White Americano/Black Americano
- Cappuccino
- Latte
- Flat White



Signature blend
Medium Roast | Smooth & Nutty
Intensity: **8** **13g**

Long coffees:

- Caffé Crema One size only



Caffé Crema blend
Dark Roast | Nutty & Biscuity
Intensity: **9**

Something sweet:

- Hot Chocolate One size only



Hot Chocolate
Rich & Creamy

Scan the QR code to access allergen & nutrition information and drink preparation SOPs/videos.



Any deviation from the approved ingredient list automatically invalidates the Nutritional & Allergen Guide. Markets must not add or substitute ingredients outside the approved list, as this introduces allergen risk & inaccurate nutritional data.

Approved additions:	Non-approved additions:
N/A	Alternative milk/s
	External syrups



Only Costa Podio capsules are compatible with this machine. Using other capsules may cause damage.



- **The cup sizes for the machine can depend on the selected drink.**
- **The espresso cup stand can be used for shorts drinks e.g. espresso and can slide left or right to allow for larger size cups for drinks e.g. cappuccino to be dispensed.**



To dispense a larger drink e.g. cappuccino, slide the espresso cup stand to either the left or right of the drink outlet.



For a better result when using espresso cups/small drinks, the espresso cup stand should be in place below the drink outlet and the cup placed on top.

3.3 Correct drink selection



- For the correct dispensing of drinks, the machine uses a fully automatic system that displays up the most appropriate drinks per capsule.
- Once the capsule has been inserted, the machine will take around 5 seconds to register the barcode in order to display the available drinks (Please see page 16 for drink offering overview).
- If a capsule is not an original Costa Coffee capsule, the machine automatically rejects it and places it in the used capsule drawer.

3.4 Dispensing a drink

- Only use Costa Coffee branded capsules.
- Use a cup suitable for the drink being dispensed, to prevent spillage from the cup.

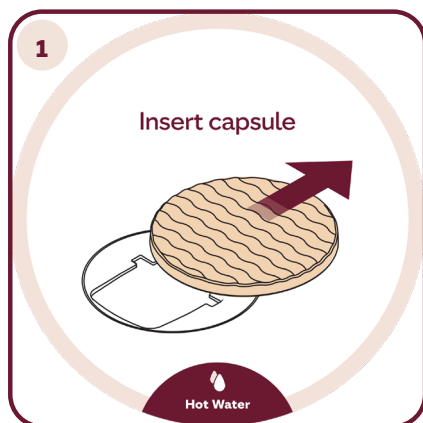

Slide the **capsule insert** back, insert the capsule into the machine, and then release. The capsule insert will slide back into position automatically.



After the capsule is inserted, the machine will display the drinks available for the capsule. **Press desired icon.**



Place desired cup under the drink outlet.



This screen will display the chosen drink and any relevant allergen information. Press **“Confirm”** to continue.

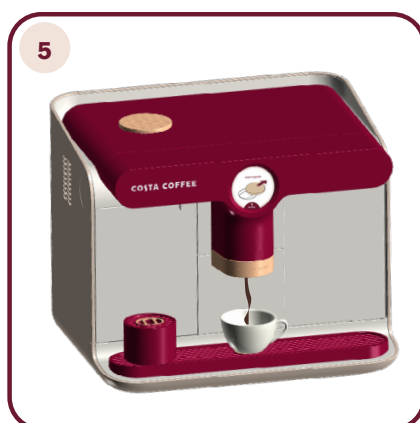

The machine proceeds with preparation of the drink. After dispensing, the machine ejects the used capsule into the capsule drawer.

The amounts of coffee and milk dispensed are programmed according to the recipes associated with each capsule and each button.

4.
Cleaning



Personal Protective Equipment (PPE)

- When completing the cleaning cycle, protective gloves and goggles must be worn.
- PPE must not be shared. It is the employer's responsibility to provide adequate supplies.
- Refer to Safety Data sheets for the safe handling of chemicals.



Costa Approved Sanitiser

- Must be diluted following manufacturers guidance.
- Ensure the manufacturers contact time is adhered to.

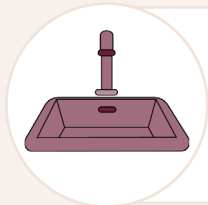

Dedicated sink

- In a food safe environment .
- Large enough to clean the water tank with hand hot, potable water.

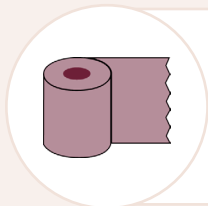

Disposable paper towels

- Always use a fresh, clean paper towel for each cleaning step.



Washing up liquid

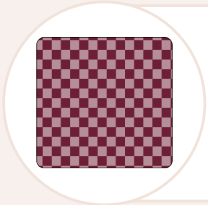

Disposable cleaning cloths

4.2 Cleaning the drink outlet:



Items required for cleaning:

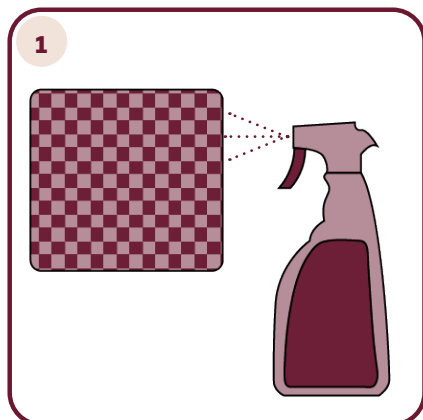
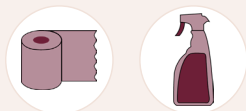

1
Spray the disposable paper towel using Costa approved sanitiser.



2
Wipe down the drink outlet to remove any build up. Dispose of paper towel.

4.3 Cleaning the removable areas:



The following cleaning task should be the same for the below areas of the machine:

Items required for cleaning:



- 1 Espresso cup stand
- 2 Drip tray
- 3 Drip tray stand
- 4 Water tanks
- 5 Capsule drawer
- 6 Internal drip tray

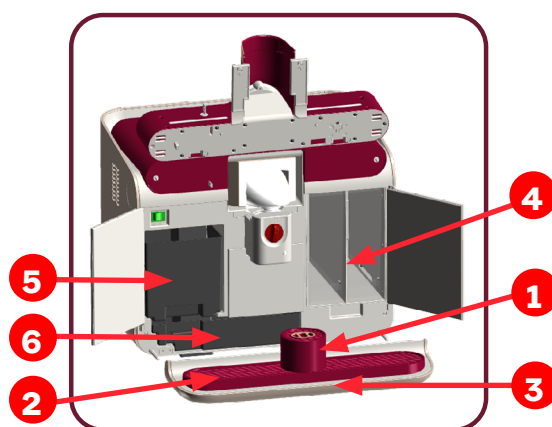

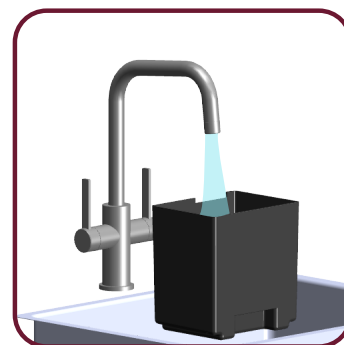
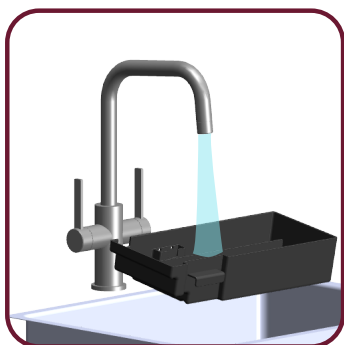
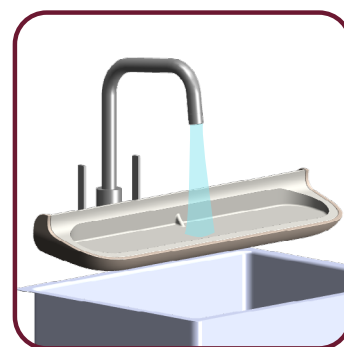
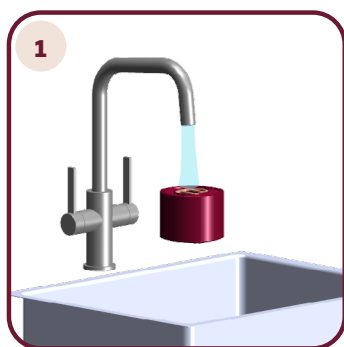

Rinse the Espresso cup stand, drip tray, drip tray stand, internal drip tray, water tanks, capsule drawer with hand hot, potable water to remove build up.

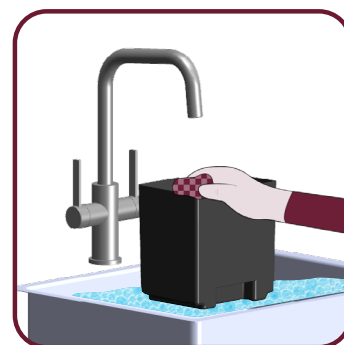
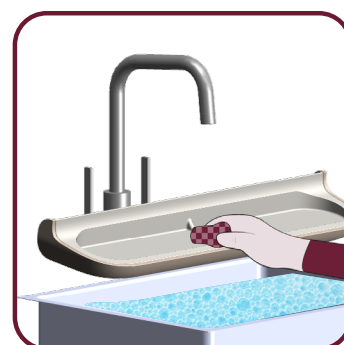

- Fill the sink with hand hot water and washing up liquid, diluted as stated by the manufacturer.
- Place the Espresso cup stand, drip tray, drip tray stand, internal drip tray, water tanks & capsule drawer into the soapy water.
- Thoroughly clean the parts in the soapy water. When all parts have been cleaned, dispose of the cleaning cloth.

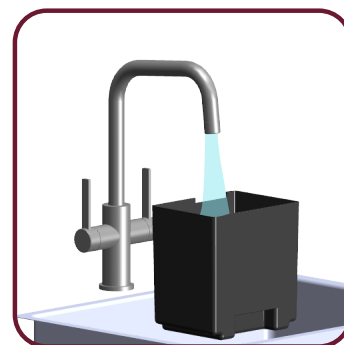
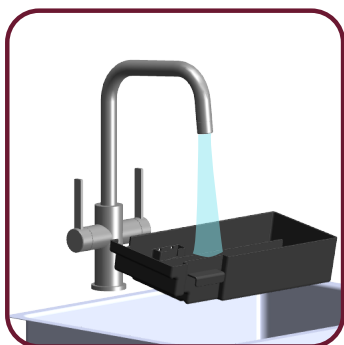
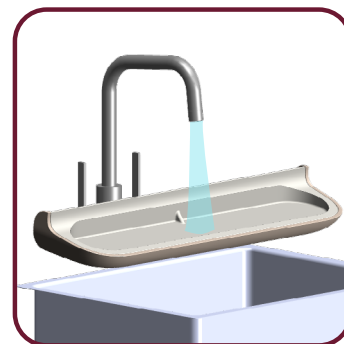
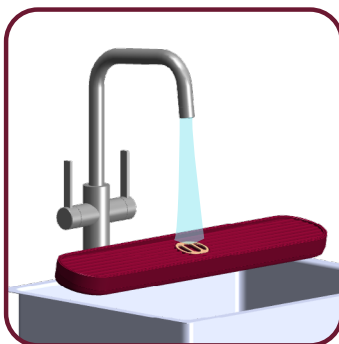
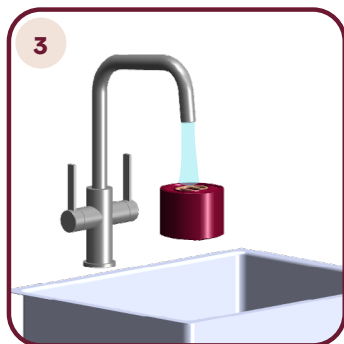

Rinse off any excessive bubbles.

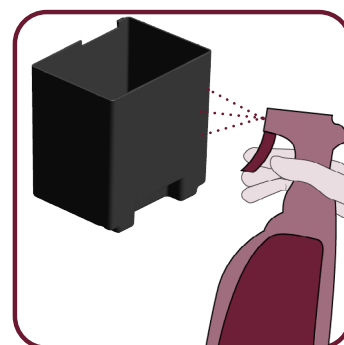
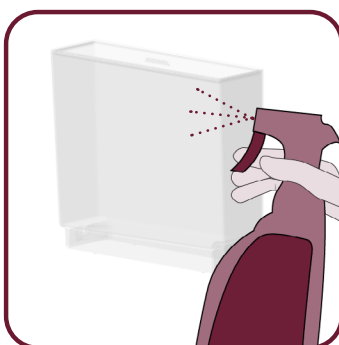
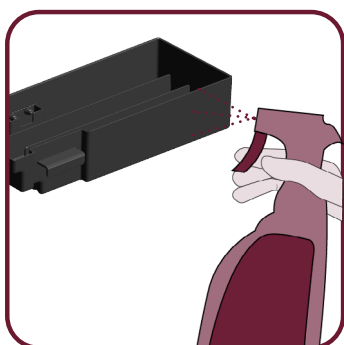
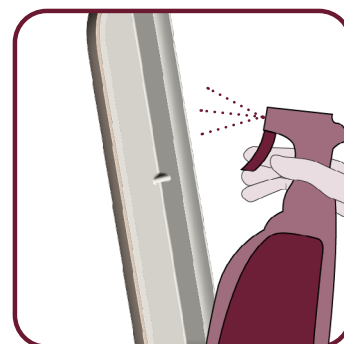
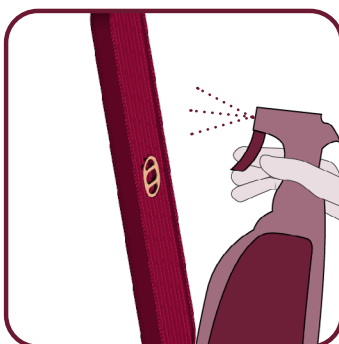
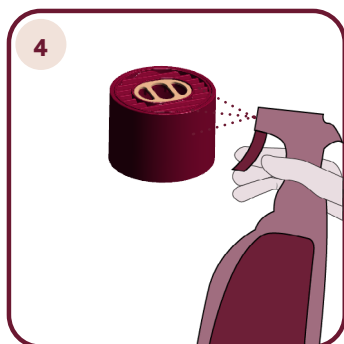

Sanitise the Espresso cup stand, drip tray, drip tray stand, internal drip tray, water tanks & capsule drawer with Costa approved sanitiser, leave in a food safe environment for the contact time stated in the manufacturers guidelines.

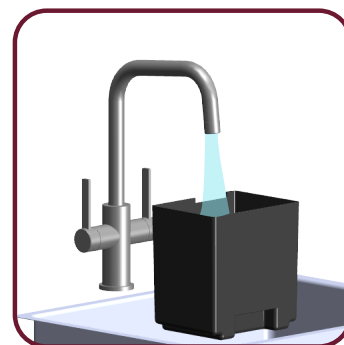
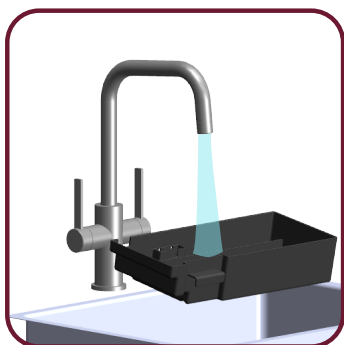
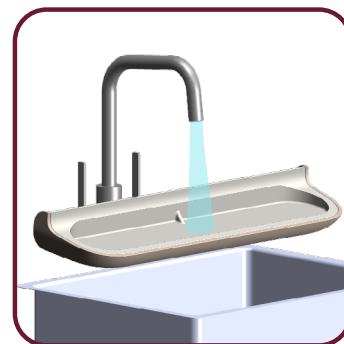
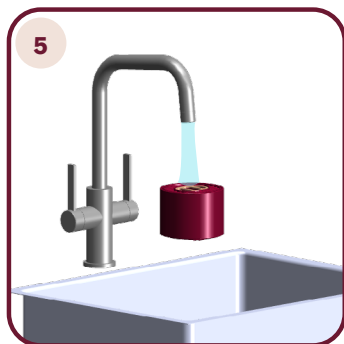

Rinse the sanitiser off and place the Espresso cup stand, drip tray, drip tray stand, internal drip tray, water tanks & capsule drawer back in the machine (wet).

4.4 Cleaning the external surfaces:

Items required for cleaning:

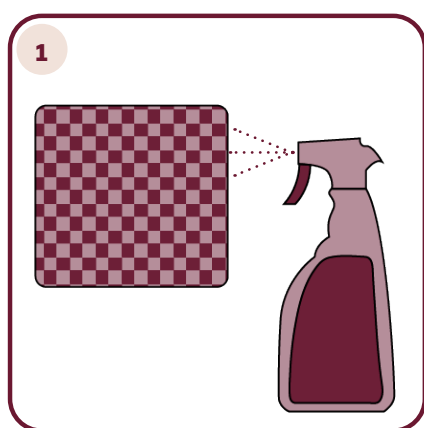
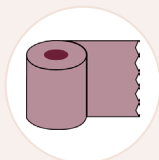

1
Spray the disposable paper towel using Costa approved sanitiser.



2
Wipe down the external surfaces with Costa approved sanitiser to remove any build up. Dispose of paper towel.

5.

Descaling

non-plumbed machines ONLY



i

- The machine has an advanced program that checks how much water is used to dispense products. This measurement provides the user with indications as to when the machine needs a descaling cycle.
- Make sure to use Caffitaly System descaler, designed to respect the machine's technical characteristics, in full compliance with consumer safety.
- The descaling solution must be disposed of according to the manufacturer's instructions and/or the regulations in force in the country of use.



- Read the directions for use on the descaler package **CAREFULLY**.
- Avoid contact with eyes, skin and machine surfaces.
- Do not turn the machine off and do not insert capsules during descaling.
- A person must be present during the operation.
- Avoid using vinegar, as it may damage the machine.

i

- When a complete descale is due an amber alert will appear on the main screen.
- The machine is still fully functional at this stage.
- It is advised to complete the complete descale as soon as possible once this alert shows.

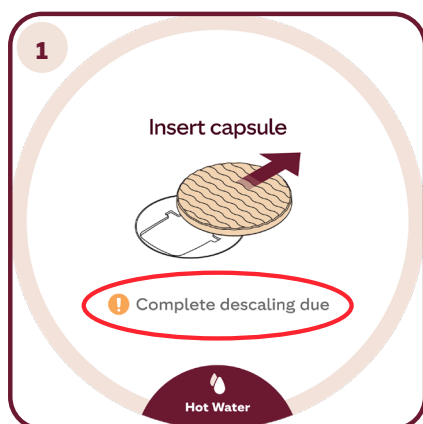

An amber alert message will appear on the main screen.

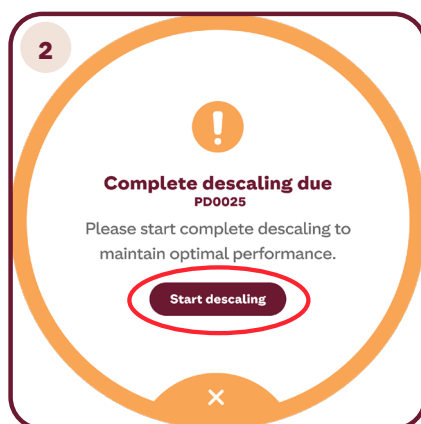

Press the **“Start descaling”** button to continue. Press the X button to cancel.



A confirmation screen will pop up, indicating that the complete descale should take approx. 40 mins to complete. Press **“Confirm”**.



Remove and empty the **drip tray**.



Remove and empty the **internal drip tray**.

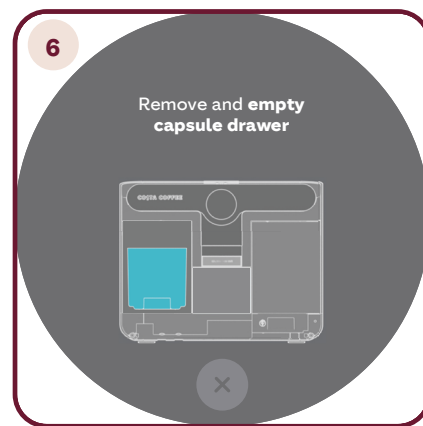

Remove and empty the **capsule drawer**.



Remove and empty **both water tanks**.

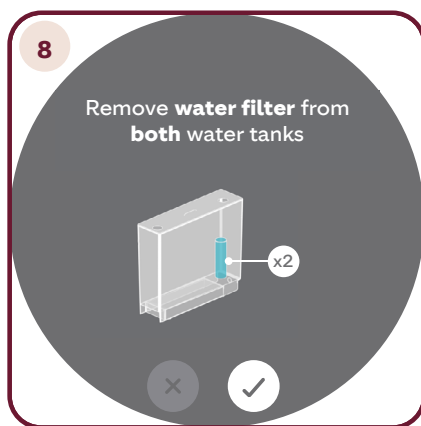

Remove **water filter** from **both water tanks**.

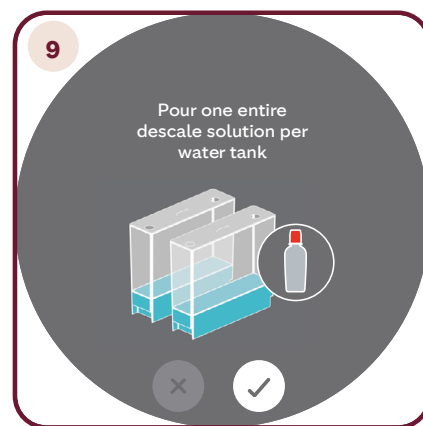

Follow on-screen instructions for amount of descale solution to add to the water tank.

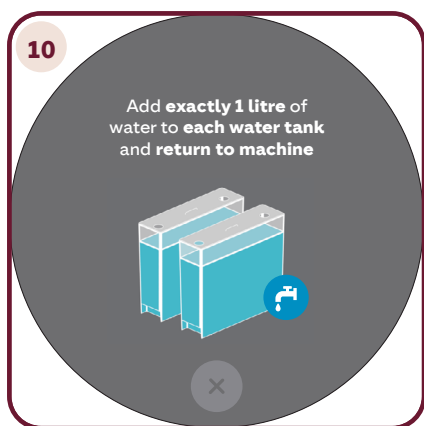

Add **exactly 1 litre** of water to **each water tank** and **return to the machine**.

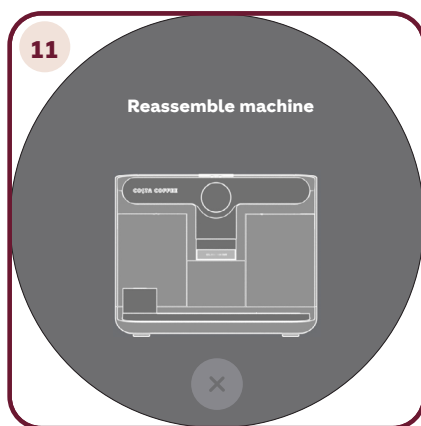

Reassemble the machine, ensuring the **capsule drawer**, **internal drip tray** & **external drip tray** are in place.



Place the **cleaning container** below the drink outlet and initiate the full descale by pressing the button.



The touch screen will display the countdown timer.

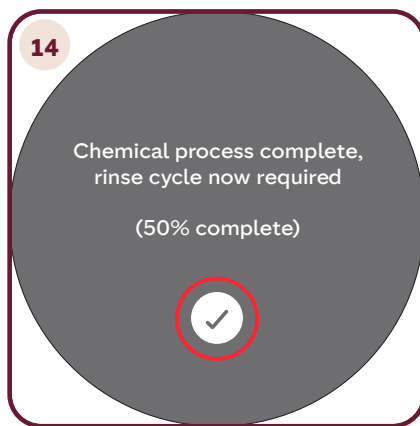

Upon completion, the machine will need to do a rinse cycle. Press the tick button.



Remove and empty the **drip tray**.

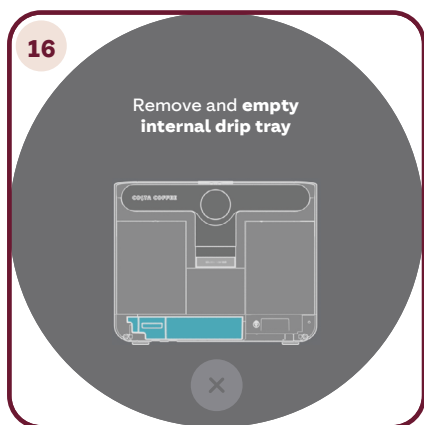

Remove and empty the **internal drip tray**.



Remove and clean **both water tanks** using diluted washing up liquid.

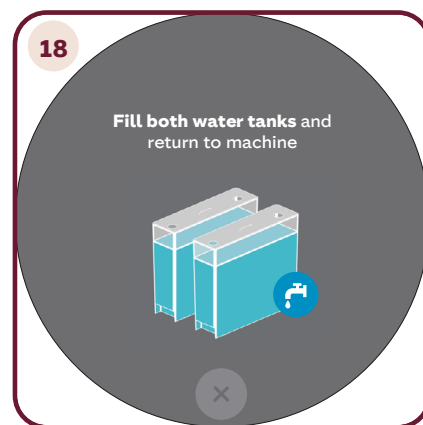

Fill **both water tanks** and return them to the machine.

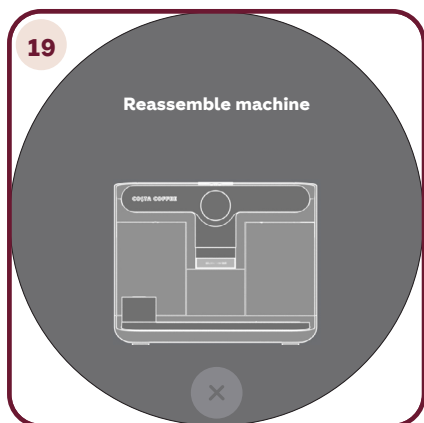

Reassemble the machine, ensuring the **capsule drawer, internal drip tray & external drip tray** are in place.



Place the **cleaning container** below the drink outlet and initiate the Descale Rinse by pressing the button circled.



The touch screen will display the countdown timer.



Remove and empty the **drip tray**.



Remove and empty the **internal drip tray**.

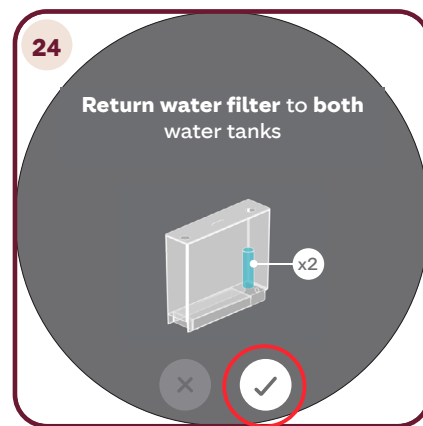

Return the **water filter** to **both water tanks**.

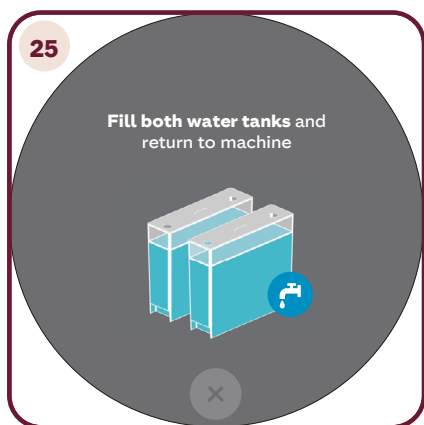

Fill **both water tanks** and return to the machine.



Reassemble the machine.



The complete descale is now complete. Press the tick button to confirm.

5.2 Thermoblock descale (non-plumbed machines ONLY):



i

- When a Thermoblock descale is due an amber alert will appear on the main screen.
- The machine is still fully functional at this stage.
- It is advised to complete the complete descale as soon as possible once this alert shows.

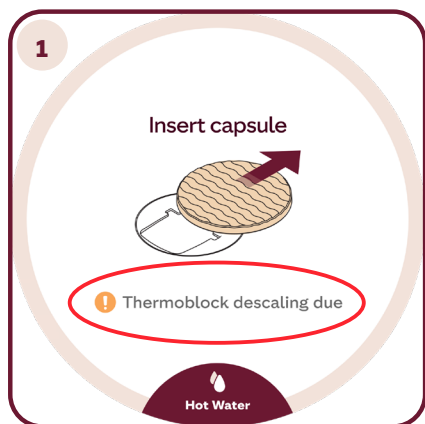

An amber alert message will appear on the main screen.

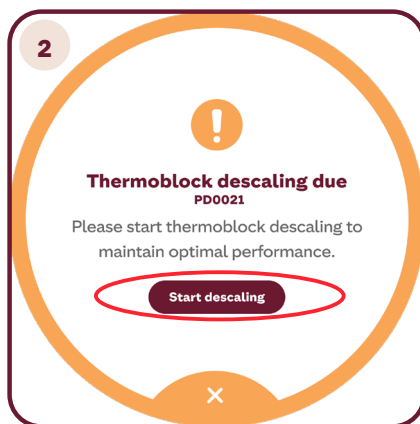

Press the **“Start descaling”** button to continue. Press the X button to cancel.



Press **“Confirm”**.

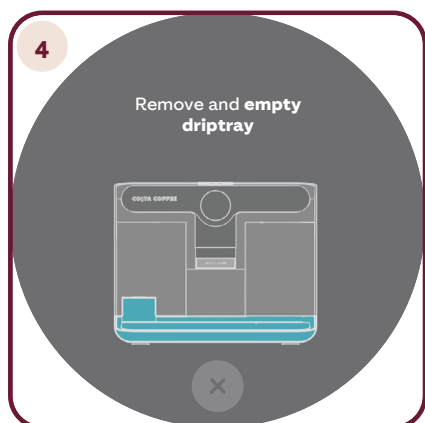

Remove and empty the **drip tray**.

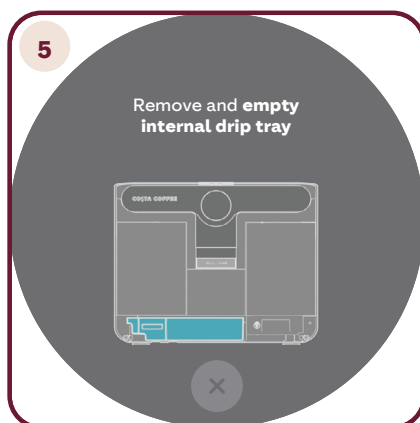

Remove and empty the **internal drip tray**.

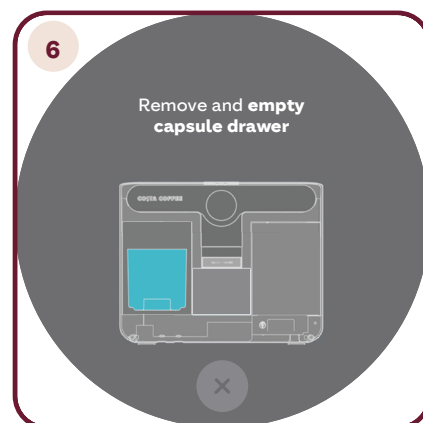

Remove and empty the **capsule drawer**.



Remove and **empty water tank 1 only (left)**.



Remove the **water filter** from water tank 1.

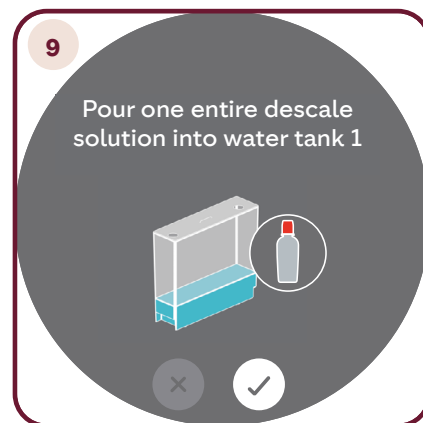

Follow on-screen instructions for amount of descale solution to add to the water tank 1.

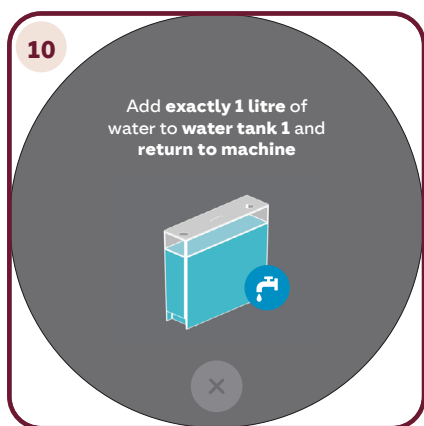

Add exactly **1 litre** of water to water tank 1 (left) and return to machine.

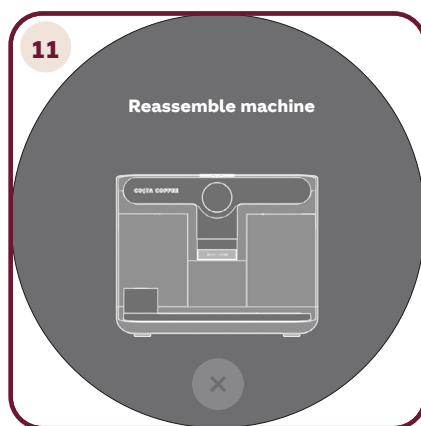

Reassemble the machine.

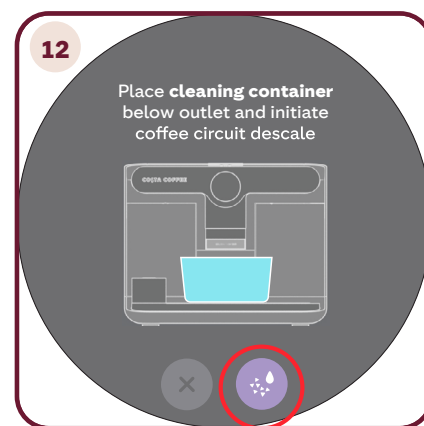

Place the cleaning container below the drink outlet and initiate the “**coffee circuit descale**” by pressing the button.



The touch screen will display the countdown timer.

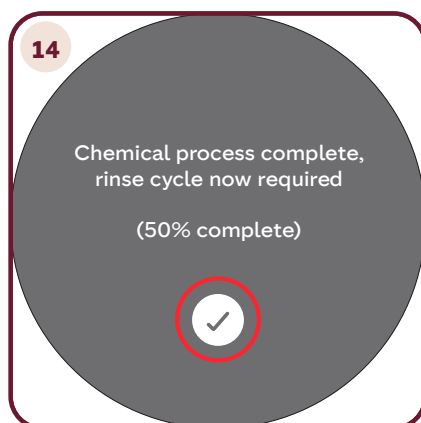

Upon completion the machine will indicate that a rinse cycle is required. Press the tick button.



Remove and empty the **internal drip tray**.

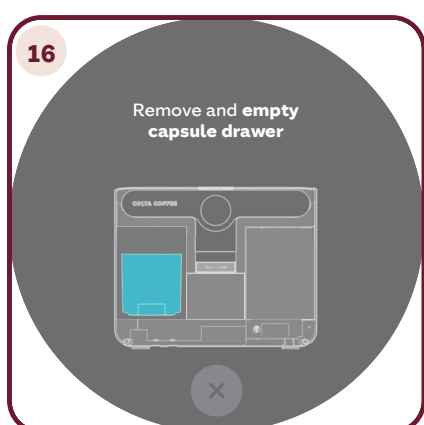

Remove and empty the **capsule drawer**.



Remove and empty the **internal drip tray**.

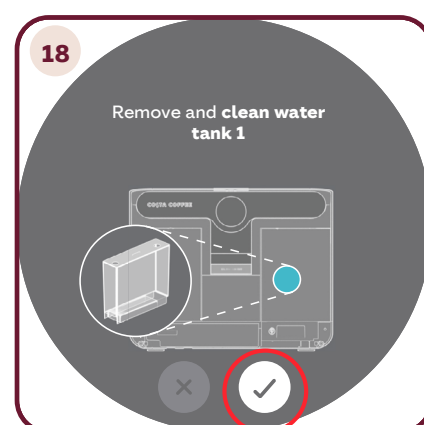

Remove and clean **water tank 1** using diluted washing up liquid.

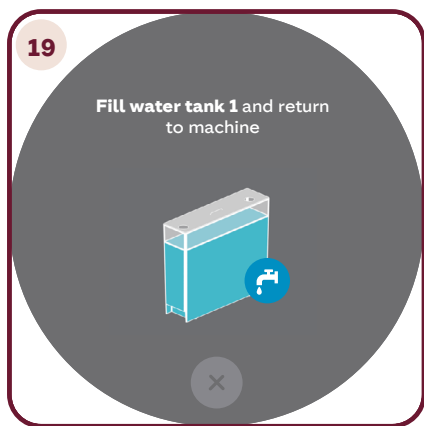

Fill **water tank 1** and return to the machine.

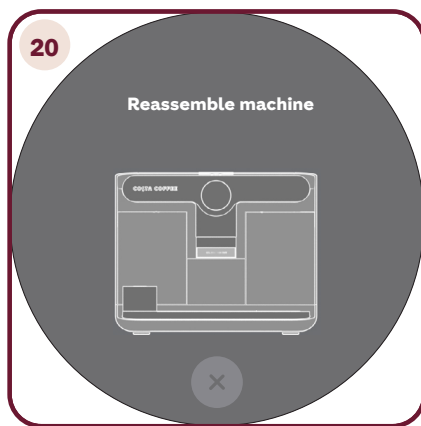

Reassemble the machine.



Place the **cleaning container** below the drink outlet and initiate the **descal rinse**.



The touch screen will display the countdown timer.



Remove and empty the **drip tray**.

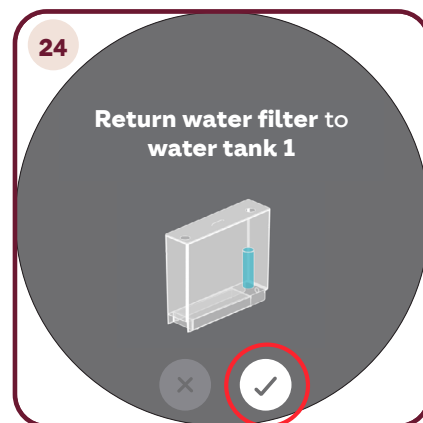

Return the **water filter** to **water tank**.

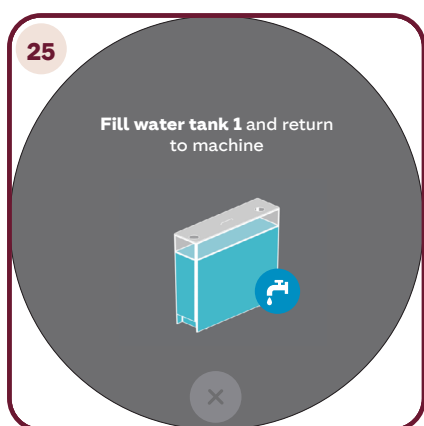

Fill **water tank** and return to the machine.

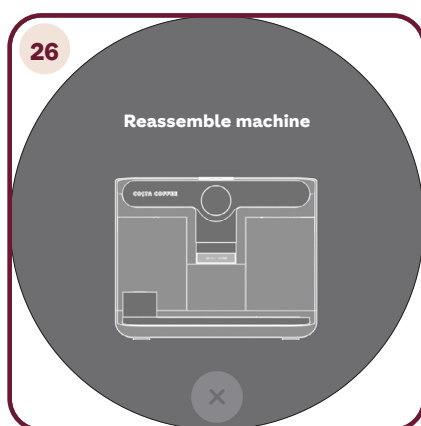

Reassemble the machine, ensuring the **capsule drawer**, **internal drip tray** and **external drip tray** are in place.



The Thermoblock descale is now complete. Press the green tick button to continue.

