

# Podio X1

MSDS and COSHH



V1.1

**COSTA**  
COFFEE  
PROFESSIONAL



PODIO





# MSDS & COSHH



## SAFETY DATA SHEET

according to Regulation (EC) No. 1907/2006  
(amended by Regulation (EU) 2020/878)

---

### Caffitaly System Descaler

---

---

#### **SECTION 1: Identification of the substance/mixture and of the company/undertaking**

##### 1.1. Product identifier

**Product name** Caffitaly System Descaler  
**Product code** 70023

##### 1.2. Relevant identified uses of the substance or mixture and uses advised against

**Use of the Substance/Mixture** Descaling agent  
**Uses advised against** The product (mixture) should not be used in combination with other cleaning/DESCALING agents.

##### 1.3. Details of the supplier of the safety data sheet

**Company/Undertaking Identification** Düring AG  
Langwiesenstrasse 1  
CH-8108 Dällikon  
Telefon +41 44 847 27 49  
[www.duringag.ch](http://www.duringag.ch)  
[www.durgol.com](http://www.durgol.com)  
  
Caffitaly System S.p.A. a socio unico  
Via Panigali, 38  
40041 Gaggio Montano (Bologna)  
Italy  
[info@caffitaly.com](mailto:info@caffitaly.com)  
Telefon: +39 0534 38911  
[www.caffitaly.com](http://www.caffitaly.com)

**1.4. Emergency telephone number** 145 (Tox Info Suisse)

**Revision date** 08.04.2025

**Version** 2

# MSDS & COSHH

---

## SECTION 2: Hazards identification

### 2.1. Classification of the substance or mixture

**Classification according to Regulation (EC) No. 1272/2008** Serious eye damage/eye irritation, Cat. 2, H319

**Additional information** For the full text of the phrases mentioned in this Section, see Section 16.

### 2.2. Label elements



**Signal Word** Warning

**Hazard Statements** H319: Causes serious eye irritation.

**Precautionary statements** P102: Keep out of reach of children.  
P302+P352: IF ON SKIN: Wash with plenty of soap and water.  
P305+P351+P338: IF IN EYES: Rinse cautiously with water for several minutes. Remove contact lenses, if present and easy to do. Continue rinsing.  
P332+P313: If skin irritation occurs: Get medical advice/attention.  
P337+P313: If eye irritation persists: Get medical advice/attention.

**Supplemental information** None.

**Product identifier** Not required.

**Contents of package < 125 ml**

Warning



**2.3. Other hazards** None known.

---

## SECTION 3: Composition/information on ingredients

### 3.2. Mixtures

Components	Weight %	CLP Classification	Product identifier
citric acid	5% - 10%	Eye Irrit. 2 H319, STOT SE 3 H335	CAS-No.: 77-92-9 EC-No.: 201-069-1 Index-No: 607-750-00-3
sulphamidic acid; sulphamic acid; sulfamic acid	5% - 10%	Eye Irrit. 2 H319, Skin Irrit. 2 H315, Aquatic Chronic 3 H412	CAS-No.: 5329-14-6 EC-No.: 226-218-8 Index-No: 016-026-00-0

For the full text of the phrases mentioned in this Section, see Section 16.

**Hazardous impurities** None known.

# MSDS & COSHH

---

## **SECTION 4: First aid measures**

### **4.1. Description of first aid measures**

<b>Inhalation</b>	Move to fresh air in case of accidental inhalation of vapours or decomposition products. Consult a physician for severe cases.
<b>Skin contact</b>	Wash off immediately with soap and plenty of water while removing all contaminated clothes and shoes. If skin irritation persists, call a physician.
<b>Eye contact</b>	Rinse immediately with plenty of water, also under the eyelids. If eye irritation persists, consult a specialist.
<b>Ingestion</b>	Clean mouth with water and drink afterwards plenty of water. Consult a physician for severe cases.

**4.2. Most important symptoms and effects, both acute and delayed**      The product contains no substances known to be hazardous to health in concentrations which need to be taken into account.

**4.3. Indication of any immediate medical attention and special treatment needed**      None known.

---

## **SECTION 5: Firefighting measures**

### **5.1. Extinguishing media**

**Suitable extinguishing media**      Use water spray, alcohol-resistant foam, dry extinguishing agent or carbon dioxide.

**Unsuitable extinguishing media**      High volume water jet.

**5.2. Special hazards arising from the substance or mixture**      During a fire, smoke may contain the original material in addition to unidentified toxic and/or irritating compounds. Collect contaminated fire extinguishing water separately. This must not be discharged into drains.

### **5.3. Advice for firefighters**

**Special protective equipment for firefighters**      Standard procedure for chemical fires. In the event of fire, wear self-contained breathing apparatus. Complete suit protecting against chemicals.

**Specific methods**      Use extinguishing measures that are appropriate to local circumstances and the surrounding environment.

# MSDS & COSHH

---

## **SECTION 6: Accidental release measures**

### **6.1. Personal precautions, protective equipment and emergency procedures**

<b>For non-emergency personnel</b>	Use personal protective equipment. Avoid contact with skin and eyes. Do not breathe vapours/dust.
<b>For emergency responders</b>	Use personal protective equipment. Do not breathe vapours/dust. Ventilate the area.

**6.2. Environmental precautions** Do not flush into surface water or sanitary sewer system.

**6.3. Methods and material for containment and cleaning up** Keep in suitable and closed containers for disposal (Plastic container of HDPE).

**6.4. Reference to other sections** See chapter 8 and 13.

---

## **SECTION 7: Handling and storage**

**7.1. Precautions for safe handling** Plan first aid action before beginning work with this product. Do not breathe vapours/dust. Avoid contact with skin and eyes.

**7.2. Conditions for safe storage, including any incompatibilities** Keep container tightly closed. Store in original container. Keep out of the reach of children.

**7.3. Specific end use(s)** No information available.

---

## **SECTION 8: Exposure controls/personal protection**

### **8.1. Control parameters**

**Exposure limit(s)** No data is available on the product itself.

**citric acid (CAS 77-92-9)**

Switzerland - Occupational Exposure Limits - Developmental Risk Groups Developmental Risk Group C

Switzerland - Occupational Exposure Limits - STELs - (KZGWs) 4 mg/m<sup>3</sup> STEL [KZGW] (inhalable dust)

Switzerland - Occupational Exposure Limits - TWAs - (MAKs) 2 mg/m<sup>3</sup> TWA [MAK] (inhalable dust)

Germany - DFG - Recommended Exposure Limits - Ceilings (Peak Limitations) 4 mg/m<sup>3</sup> Peak (respirable fraction)

Germany - DFG - Recommended Exposure Limits - Pregnancy no risk to embryo/fetus if exposure limits adhered to

Germany - DFG - Recommended Exposure Limits - TWAs (MAKs) 2 mg/m<sup>3</sup> TWA MAK I(2) (inhalable fraction)

Germany - TRGS 900 - Occupational Exposure Limits - 2 mg/m<sup>3</sup> TWA AGW (the risk of damage to the embryo or fetus can be excluded when AGW and BGW values are observed, inhalable

# MSDS & COSHH

TWAs (AGWs) fraction, exposure factor 2)

## 8.2. Exposure controls

**Appropriate engineering controls** Handle in accordance with good industrial hygiene and safety practice.

### Personal protection equipment

*Respiratory protection* No personal respiratory protective equipment normally required.

*Hand protection* Special skin protection is not required. Direct skin contact with the product should be avoided.

*Eye protection* Normally no eye protection necessary.

*Skin and body protection* No special protective equipment is required.

*Thermal hazards* Does not sustain combustion.

**Environmental exposure controls** Prevent product from entering surface water or sewage.

---

## ***SECTION 9: Physical and chemical properties***

### 9.1. Information on basic physical and chemical properties

<b>Physical state</b>	Liquid.
<b>Colour</b>	Colourless.
<b>Odour</b>	Characteristic.
<b>Melting point/ freezing point:</b>	0 °C - 100 °C
<b>Boiling point or initial boiling point / range:</b>	100 °C
<b>Flammability:</b>	Not determined.
<b>Lower and upper explosion limit:</b>	None.
<b>Flash point:</b>	does not flash
<b>Auto-ignition temperature:</b>	None.
<b>Decomposition temperature:</b>	Not determined.
<b>pH:</b>	Not applicable.
<b>Kinematic viscosity:</b>	Not determined.
<b>Solubility:</b>	completely soluble (Water)
<b>Partition coefficient n-octanol/water (log value):</b>	Not determined.
<b>Vapour pressure:</b>	Not determined.
<b>Density and/or relative density:</b>	Not determined.
<b>Relative vapour density:</b>	Not determined.
<b>Particle characteristics:</b>	Not applicable.

### 9.2. Other information

**9.2.1 Information with regard to physical hazard classes** None.

**9.2.2 Other safety characteristics** None.

# MSDS & COSHH

---

## SECTION 10: Stability and reactivity

<b>10.1. Reactivity</b>	Reacts with strong oxidizing agents and alkalis, generating heat. Reacts with carbonates to form carbon dioxide.
<b>10.2. Chemical stability</b>	No decomposition if used as directed.
<b>10.3. Possibility of hazardous reactions</b>	Exothermic reaction with strong bases.
<b>10.4. Conditions to avoid</b>	Burning produces obnoxious and toxic fumes.
<b>10.5. Incompatible materials</b>	Acid-labile plastics (POM), low-grade chrome steel, thin/damaged chrome plating, silver and marble can be attacked.
<b>10.6. Hazardous decomposition products</b>	None reasonably foreseeable.

---

## SECTION 11: Toxicological information

### 11.1. Information on toxicological effects

<b>Acute toxicity</b>	<b>citric acid (CAS 77-92-9)</b> Dermal LD50 Rat > 2000 mg/kg (EU_CLH) Oral LD50 Rat = 3 g/kg (NLM_CIP) <b>sulphamidic acid; sulphamic acid; sulfamic acid (CAS 5329-14-6)</b> Dermal LD50 Rat > 2000 mg/kg (ECHA_API) Oral LD50 Rat = 2140 mg/kg (ECHA)
<b>Skin corrosion/irritation</b>	Mild skin irritation.
<b>Serious eye damage/eye irritation</b>	Causes serious eye irritation.
<b>Respiratory or skin sensitisation</b>	None.
<b>Carcinogenicity</b>	Based on available data, the classification criteria are not met.
<b>Germ cell mutagenicity</b>	Based on available data, the classification criteria are not met.
<b>Reproductive toxicity</b>	Based on available data, the classification criteria are not met.
<b>Specific target organ toxicity - Single exposure</b>	No data available.
<b>Specific target organ toxicity - Repeated exposure</b>	No data available.
<b>Aspiration hazard</b>	No data available.
<b>Human experience</b>	No data available.

# MSDS & COSHH

## 11.2. Information on other hazards

**Endocrine disrupting properties** No data available.

**Other information** No data available.

---

## **SECTION 12: Ecological information**

**12.1. Toxicity** May change pH of waters.

**citric acid (CAS 77-92-9)**

EU - Ecolabel (66/2010) - Detergent Ingredient Database - Aerobic Degradation Readily biodegradable according to OECD guidelines.

EU - Ecolabel (66/2010) - Detergent Ingredient Database - Anaerobic Degradation

Biodegradable under anaerobic conditions.

Ecotoxicity - Freshwater Fish - Acute Toxicity Data

LC50 96 h *Lepomis macrochirus* 1516 mg/L (OECD\_SIDS)

**sulphamidic acid; sulphamic acid; sulfamic acid (CAS 5329-14-6)**

Ecotoxicity - Freshwater Fish - Acute Toxicity Data

LC50 96 h *Pimephales promelas* 14.2 mg/L [static] (EPA)

**12.2. Persistence and degradability**

Neutralization is normally necessary before waste water is discharged into water treatment plants.

**12.3. Bioaccumulative potential**

Bioaccumulation is unlikely.

**12.4. Mobility in soil**

No data available.

**12.5. Results of PBT and vPvB assessment**

No data available.

**12.6. Endocrine disrupting properties**

No data available.

**12.7. Other adverse effects**

No data available.

---

## **SECTION 13: Disposal considerations**

### **13.1. Waste treatment methods**

**Waste from residues / unused products**

Dispose of in accordance with local regulations.

**Contaminated packaging**

Dispose of as unused product.

# MSDS & COSHH

---

## SECTION 14: Transport information

14.1. UN number or ID number	Not applicable.
14.2. UN proper shipping name	Not applicable.
14.3. Transport hazard class(es)	Not applicable.
14.4. Packing group	Not applicable.
14.5. Environmental hazards	Not applicable.
14.6. Special precautions for user	Not applicable.
14.7. Maritime transport in bulk according to IMO instruments	Not applicable.

### UN Model Regulations

ADR/RID	Not regulated.
IMDG	Not regulated.
IATA	Not regulated.
Further Information	None.

---

## SECTION 15: Regulatory information

### 15.1. Safety, health and environmental regulations/legislation specific for the substance or mixture

<b>Regulatory Information citric acid (CAS 77-92-9)</b>	None.
Switzerland - Biocides - Annex II - Active Substances - Minimum Purity	995 g/kg Sunset Date: 02/28/2028
Switzerland - Biocides - Annex II - Active Substances - Product Type	Product Type: 2
Switzerland - Chemical Risk Reduction Ordinance - Prohibited and Restricted Substances	"Use restricted. See annex 2.12 in the regulation (in liquid phase or solution)" As Acids [RR-08658-8]
EU - Biocides (2007/565/EC) - Substances and Product-Types Not to Be Included in Annexes I, IA and IB to Directive 98/8/EC	Product type: 2 Product type: 3
EU - Biocides (528/2012/EU) - Active Substances	2 - Disinfectants and algacides not intended for direct application to humans or animals (Commission Implementing Regulation 2016/1938/EU) 6 - Preservatives for products during storage (Commission Delegated Regulation 2021/407/EU)
EU - REACH (1907/2006) - Annex XVII - Restrictions on Certain Dangerous Substances	Use restricted. See entry 75.
EU - REACH (1907/2006) - List of Registered Substances	Present

# MSDS & COSHH

Germany - Water Classification - Substances According to AwSV Classified By or Based on the VwVwS	Reg. no. 57, hazard class 1 - slightly hazardous to water
UNEP (United Nations Environment Programme) - Basel Convention - Hazardous Wastes - Annex I	"Y34 (solid or solution, listed under Acidic solutions or acids in solid form)" As Acids [RR-08658-8]
<b>sulphamidic acid; sulphamic acid; sulfamic acid (CAS 5329-14-6)</b>	
EU - REACH (1907/2006) - Annex XVII - Restrictions on Certain Dangerous Substances	Use restricted. See entry 75.
EU - REACH (1907/2006) - List of Registered Intermediates	Present ([226-218-8])
EU - REACH (1907/2006) - List of Registered Substances	Present
Germany - Water Classification - Substances According to AwSV Classified By or Based on the VwVwS	Reg. no. 1266, hazard class 1 - slightly hazardous to water
<b>15.2. Chemical safety assessment</b>	Not required.

---

## **SECTION 16: Other information**

<b>Key or legend to abbreviations and acronyms</b>	None.
<b>Full text of phrases referred to under sections 2 and 3</b>	H315: Causes skin irritation. H319: Causes serious eye irritation. H335: May cause respiratory irritation. H412: Harmful to aquatic life with long lasting effects.
<b>Further information</b>	Take notice of the directions of use on the label.
<b>Disclaimer</b>	The information provided in this Safety Data Sheet is correct to the best of our knowledge, information and belief at the date of its publication. The information given is designed only as a guidance for safe handling, use, processing, storage, transportation, disposal and release and is not to be considered a warranty or quality specification. The information relates only to the specific material designated and may not be valid for such material used in combination with any other materials or in any process, unless specified in the text.

# MSDS & COSHH



LAICA spa

DOCUMENT CODE	EOBAB04	EDITION NUMBER	01	DATE	08/11/2021
---------------	---------	----------------	----	------	------------

**DESCRIPTION: LAICA WATER SYSTEM FOR COFFEE MACHINE**

**COMMERCIAL NAME: LAICA POWER BLU**

**TYPE CODE (3D) : POWER\_P08A**

## PRODUCT SPECIFICATION



Written by: Franco Uva R&D  
Checked by:  
Reviewed by:  
Approved by:

**CONFIDENTIALITY and WARNING NOTICE:** this documents contain legally privileged or confidential information. Any dissemination, distribution and copyng of the contents of this document is strictly forbidden.



# MSDS & COSHH



LAICA spa

DOCUMENT CODE	E0BAB04	EDITION NUMBER	01	DATE	08/11/2021
---------------	---------	----------------	----	------	------------

## 3. BILL OF MATERIAL

CONFIGURAZIONE TIPO STANDARD

ITEM	Q.TA'	DESCRIPTION	3D CODE	MATERIAL	WEIGHT (gr)	CODE	
0	1	Assembly	power_p08a	-			
1	1	main body	power_m08a	PP	17	EBIC010	
2	1	top	power_l02a	PP	7	ETOP009	
5	1	seal	power_r03a	SEBS	1,5	EGUR005	
3	1	Insert	power_s01a	PP	8,6	EINS002	

## 3.1 DRAWINGS

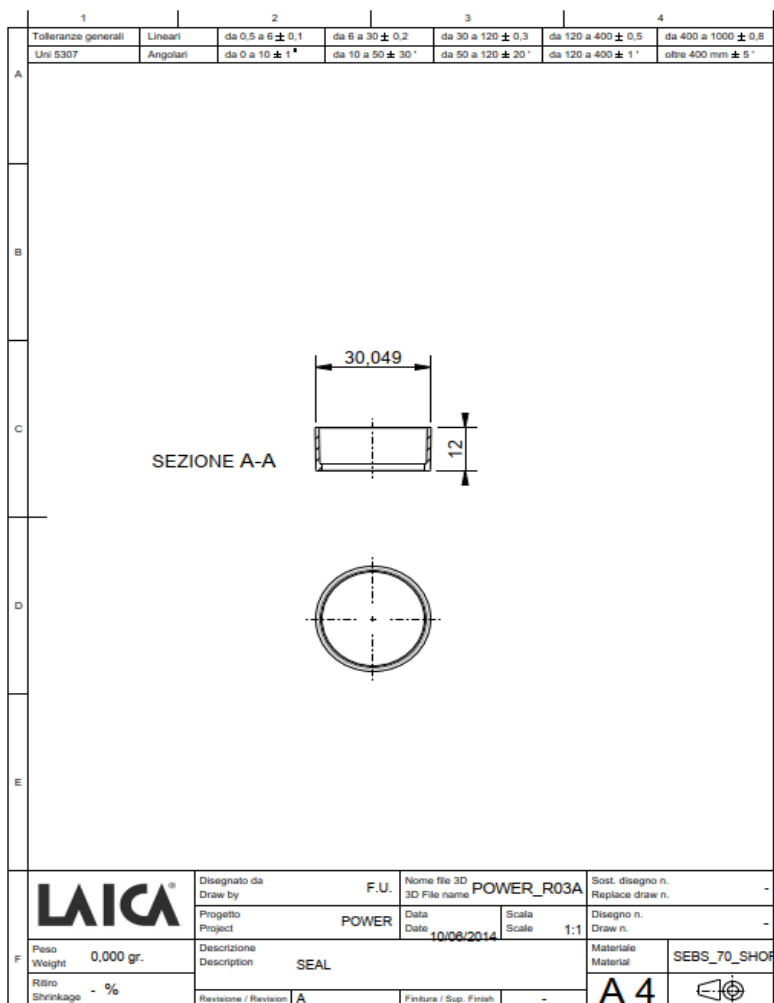

Written by: Franco Uva R&D  
 Checked by:  
 Reviewed by  
 Approved by:

CONFIDENTIALITY and WARNING NOTICE: this documents contain legally privileged or confidential information. Any dissemination, distribution and copying of the contents of this document is strictly forbidden.

# MSDS & COSHH



LAICA spa

DOCUMENT CODE	E0BAB04	EDITION NUMBER	01	DATE	08/11/2021
---------------	---------	----------------	----	------	------------

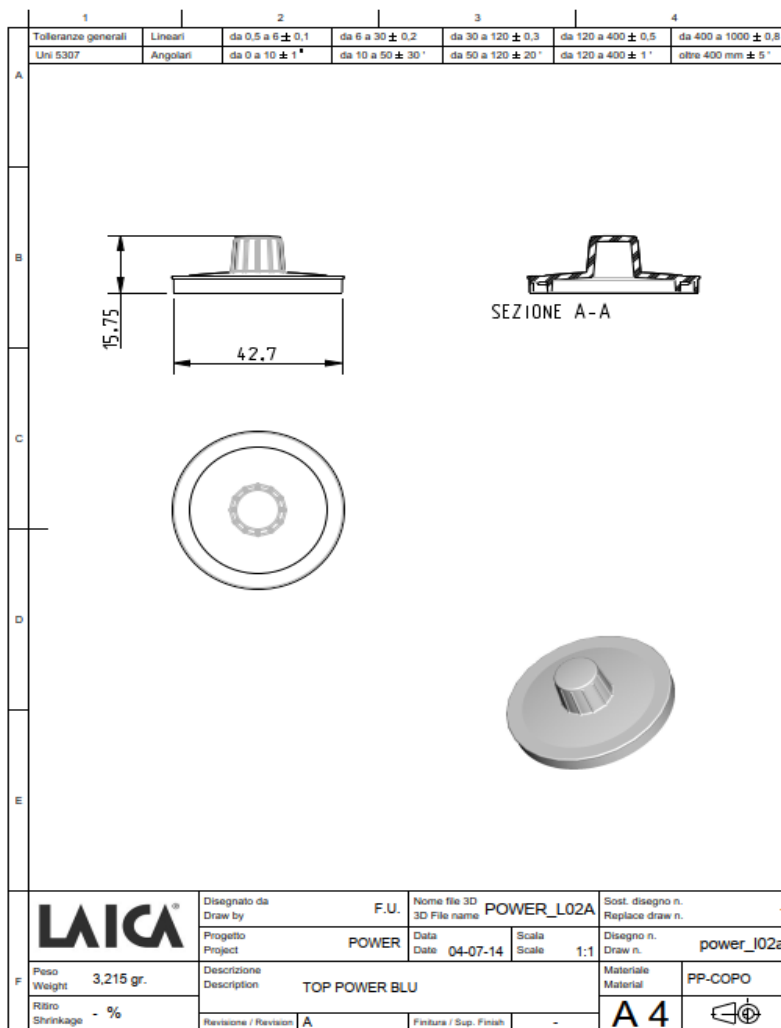

Written by: Franco Uva R&D  
 Checked by:  
 Reviewed by  
 Approved by:

CONFIDENTIALITY and WARNING NOTICE: this documents contain legally privileged or confidential information. Any dissemination, distribution and copying of the contents of this document is strictly forbidden.

# MSDS & COSHH



LAICA spa

DOCUMENT CODE	E0BAB04	EDITION NUMBER	01	DATE	08/11/2021
---------------	---------	----------------	----	------	------------

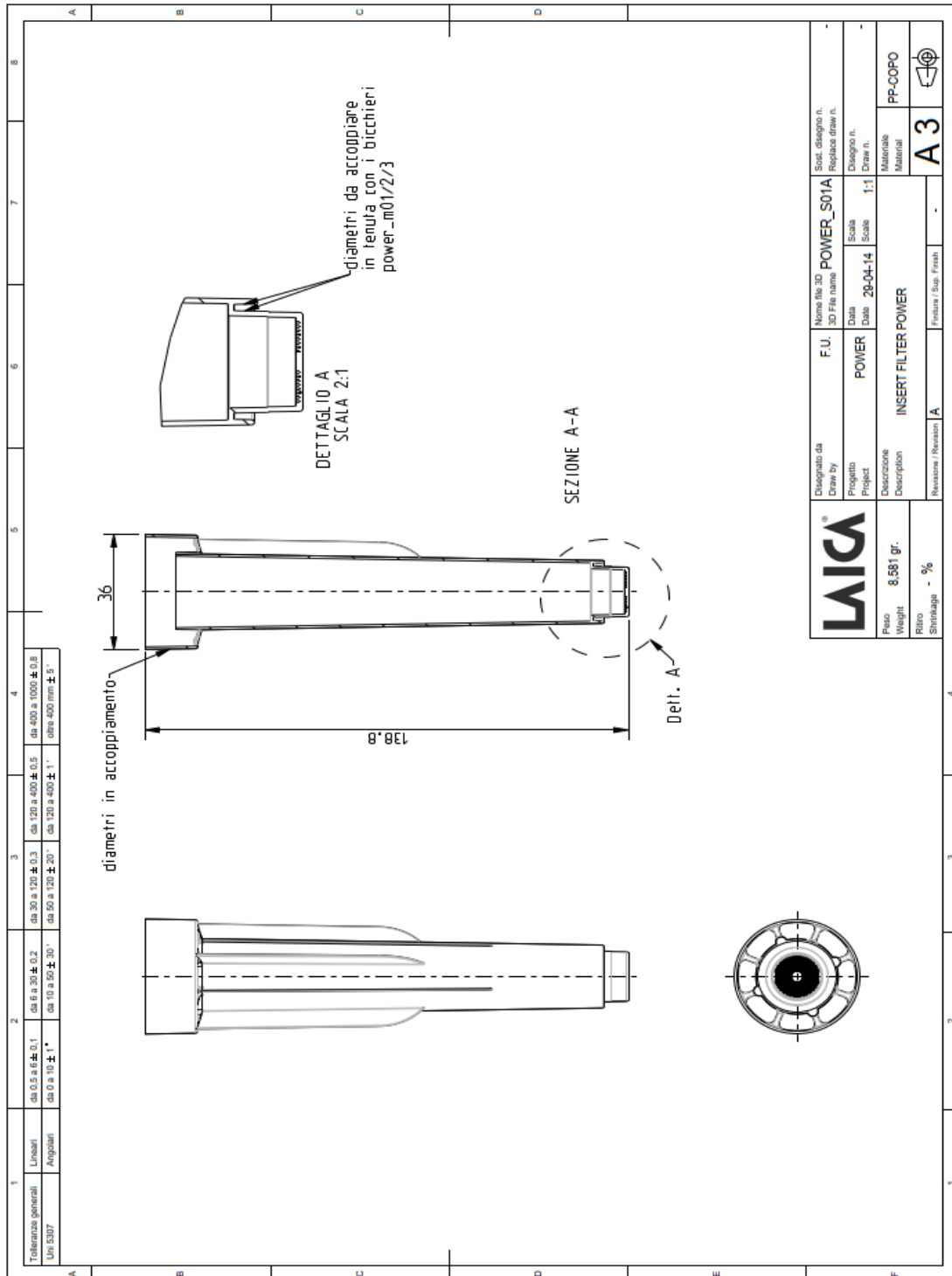

Written by: Franco Uva R&D Checked by: Reviewed by Approved by:	<b>CONFIDENTIALITY and WARNING NOTICE:</b> this documents contain legally privileged or confidential information. Any dissemination, distribution and copying of the contents of this document is strictly forbidden.
--	---

# MSDS & COSHH



LAICA spa

DOCUMENT CODE	E0BAB04	EDITION NUMBER	01	DATE	08/11/2021
---------------	---------	----------------	----	------	------------

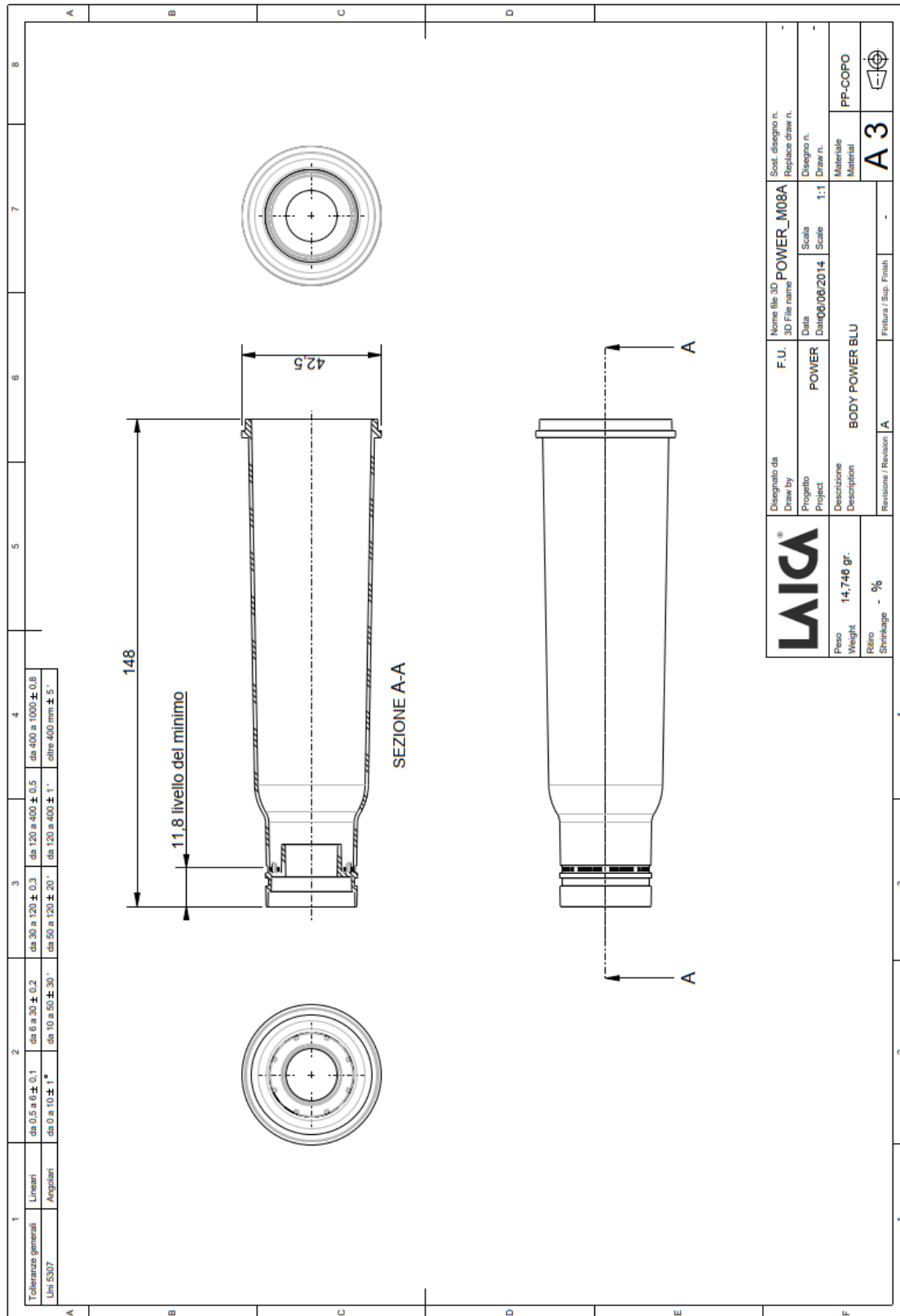

Written by: Franco Uva R&D	CONFIDENTIALITY and WARNING NOTICE: this documents contain legally privileged or confidential information. Any dissemination, distribution and copying of the contents of this document is strictly forbidden.
Checked by:	
Reviewed by:	
Approved by:	

# MSDS & COSHH

 <b>LAICA spa</b>					
<b>DOCUMENT CODE</b>	E0BAB04	<b>EDITION NUMBER</b>	01	<b>DATE</b>	08/11/2021

## 2. MAIN FEATURES AND PERFORMANCE

### 2.1 VACUUM TEST

Performance of vibration pump type :Ulka EP5 250 volt 50 hz 48w.  
Please note: The performance of the pump have a tolerance range about 10%

P	FILTER TYPE									
	A1/00		A1/13		A1/14		CLARIS		NO FILTER	
	Q	V	Q	V	Q	V	Q	V	Q	V
0	396	-46	525,0	-33,5	527,5	-35	588	-12	585	
2,5	315	-37	346,0	-23,0	340	-24	364,5	-10	370	
5	235	-30	241,0	-17,0	243	-19	255	-6,5	248	
7	193	-24,5	187,0	-14,0	185	-15	188	-6	182	
8	170	-21,5	166,0	-13,0	155	-13,5	167	-5	170	
10	122	-12	100,0	-9,0	108	-9,5	113	-3	100	
13	50	-4,8	48,0	-4,0	47	-3,5	46	-1	50	

Legend: A1/00;A1/13;A1/14 (see lab chimico)

P= pression measured in pump output (5), bar

Q= Flow rate, cc/1'

V= Vacuum level measured in pump input (3), Kpa

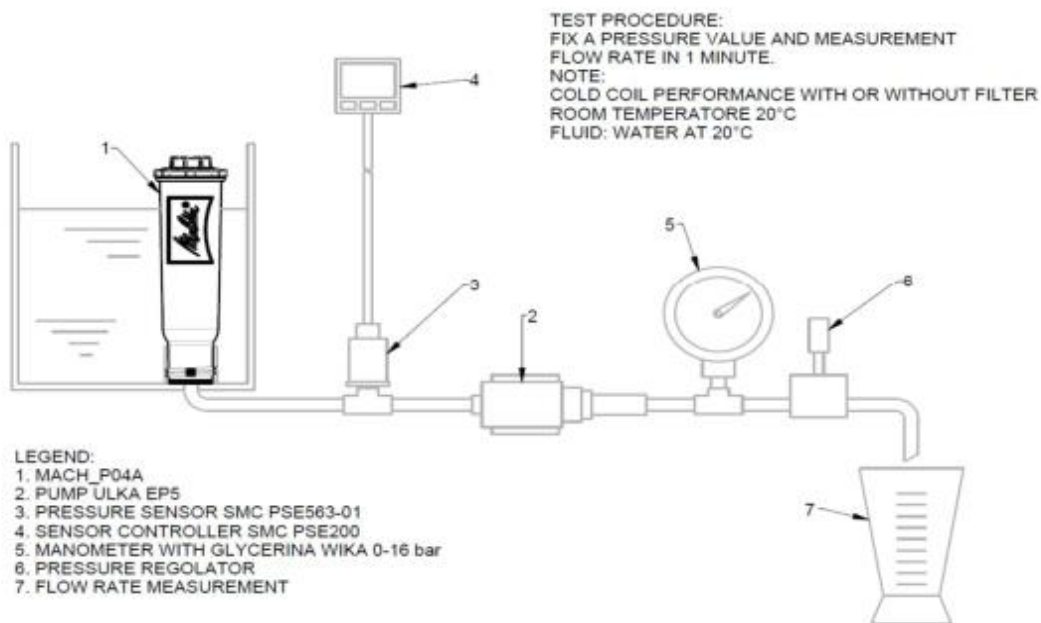

Written by: Franco Uva R&D  
Checked by:  
Reviewed by:  
Approved by:

CONFIDENTIALITY and WARNING NOTICE: this documents contain legally privileged or confidential information. Any dissemination, distribution and copyng of the contents of this document is strictly forbidden.

# MSDS & COSHH



LAICA spa

DOCUMENT CODE	EOBAB04	EDITION NUMBER	01	DATE	08/11/2021
---------------	---------	----------------	----	------	------------

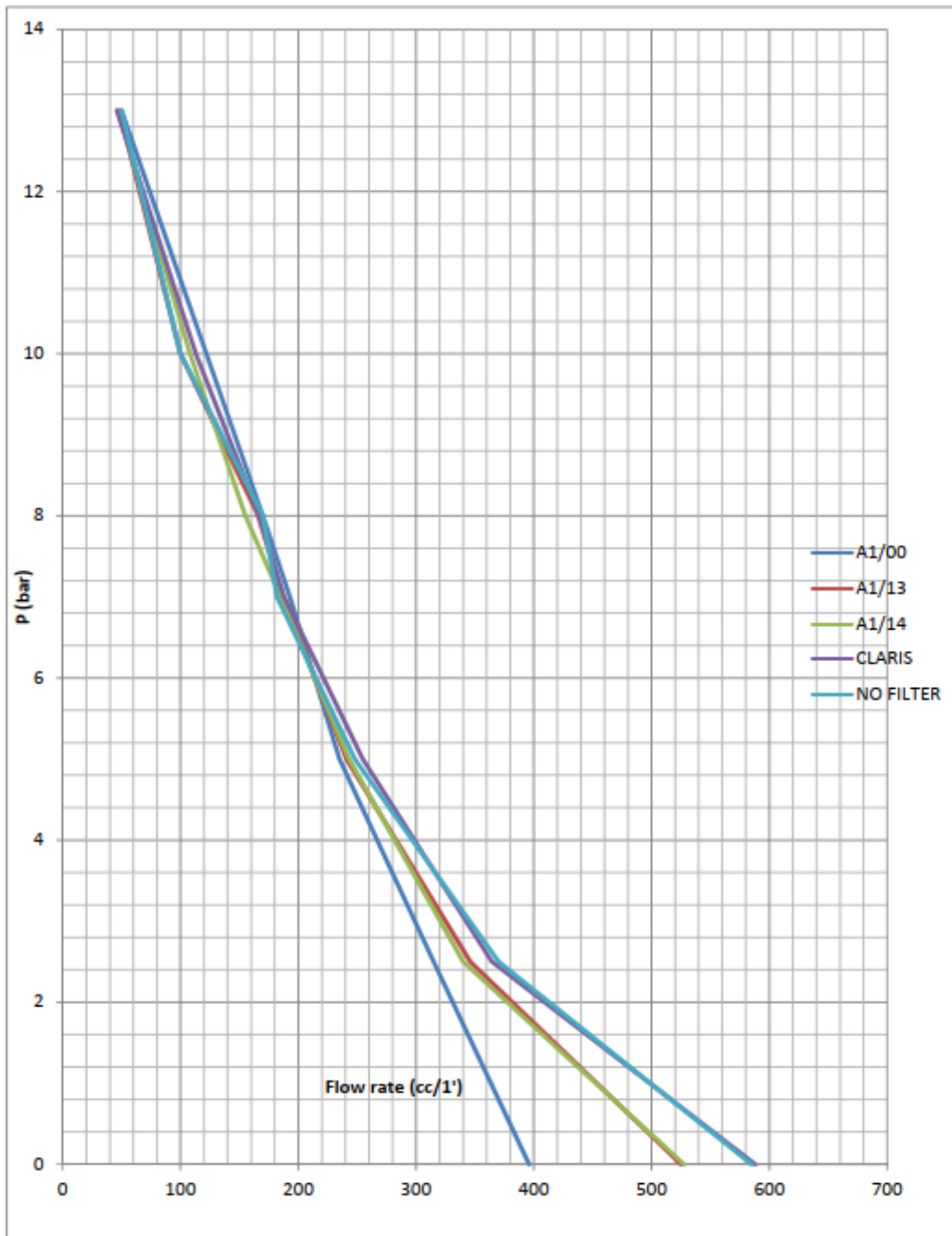

Written by: Franco Uva R&D  
Checked by:  
Reviewed by:  
Approved by:

CONFIDENTIALITY and WARNING NOTICE: this documents contain legally privileged or confidential information. Any dissemination, distribution and copyng of the contents of this document is strictly forbidden.

# MSDS & COSHH



LAICA spa

DOCUMENT CODE	E0BAB04	EDITION NUMBER	01	DATE	08/11/2021
---------------	---------	----------------	----	------	------------

Pressure drop diagram of Laica water filter system type power\_p04a.

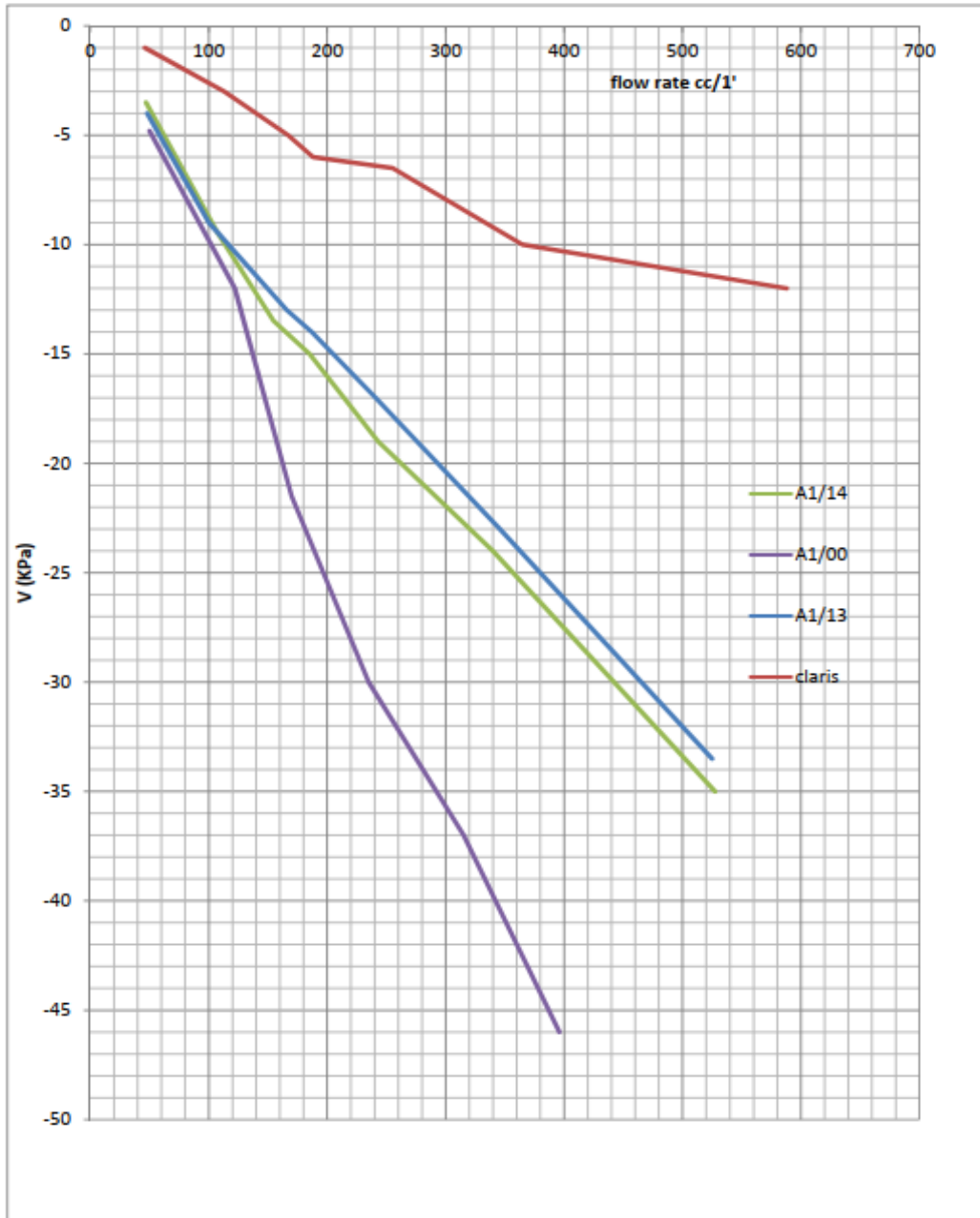

Written by: Franco Uva R&D  
Checked by:  
Reviewed by:  
Approved by:

CONFIDENTIALITY and WARNING NOTICE: this documents contain legally privileged or confidential information. Any dissemination, distribution and copyng of the contents of this document is strictly forbidden.

# MSDS & COSHH



LAICA spa

DOCUMENT CODE	E0BAB04	EDITION NUMBER	01	DATE	08/11/2021
---------------	---------	----------------	----	------	------------

Vacuum test in Melitta coffee machine type Caffeo Solo

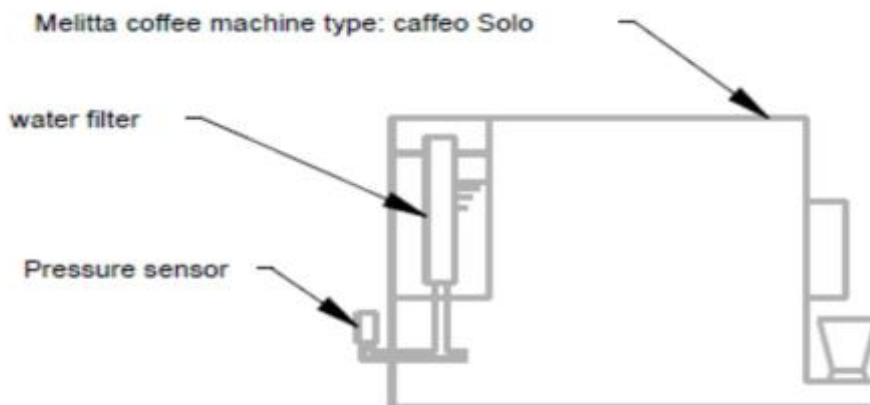

FILTER TYPE	lordo	tara	netto
B1/14	127,5	29,2	98,3
claris	108	24	83,8

	cycle time s.	preparation time s.	dispensed time s.	Q/media (cc/1') no filtro	Q media B1/14	vacuum media Kpa
min	27	20	7	223	177	-19,5
med	53	20	33	240,9	217	-22
max	70	20	50	261,6	254	-20

DECLARATION FROM FABBRICANT			
REGULATOR	MIN	MED	MAX
DISPENSED QUANTITY (cc)	30	125	220

Written by: Franco Uva R&D	CONFIDENTIALITY and WARNING NOTICE: this documents contain legally privileged or confidential information. Any dissemination, distribution and copyng of the contents of this document is strictly forbidden.
Checked by:	
Reviewed by:	
Approved by:	

# MSDS & COSHH



LAICA spa

DOCUMENT CODE	E0BAB04	EDITION NUMBER	01	DATE	08/11/2021
---------------	---------	----------------	----	------	------------

DISPENSED COMPARATION TEST																									
		06/05/2014			14/05/2014																				
filter type	Regulator	vacuum (Kpa)	Quantity (cc)	Media	Quantity (cc)	Vacuum (Kpa)	Quantity (cc)	Vacuum (Kpa)	Quantity (cc)	Vacuum (Kpa)	Quantity (cc)	Vacuum (Kpa)	Quantity (cc)	Vacuum (Kpa)											
no	min		24	26,1	29																				
no	min		25			28																			
no	min		27																						
no	min		29,5																						
no	min		25																						
no	med	/	134,5	132,5	132,5	/	/	/	/	/	/	/	/	/											
no	med		132		132,8																				
no	med		131																						
no	max		221												220,3										
no	max		221												222,8										
no	max		226,5																						
no	max		222																						
no	max		223																						
no	max		194,5																						
B1/00	min	-43	21	20,5																					
B1/00	min	-45	20																						
B1/00	med	-46	110	110																					
B1/00	max	-46	192																						
B1/00	max	-46	190,5	189,3																					
B1/00	max	-45	185,5																						
B1/13	min	-32	20	20	24	-27																			
B1/13	med	-35	110	110	116	-30																			
B1/13	max	-36	202,5	201	205	-30																			
B1/13	max	-36	200		203	-30																			
B1/14	min	-20	17,52	20,67	25	-14																			
B1/14	min	-20	16			26,7	-14																		
B1/14	min	-20	19,64																						
B1/14	min	-20	20																						
B1/14	min	-20	24																						
B1/14	min	-16	26,5																						
B1/14	min	-21	21																						
B1/14	med	-22	120	119,5	132,5	-10																			
B1/14	med	-22	119		132,8	-11																			
B1/14	max	-22	205	212,4	225	-12																			
B1/14	max	-23	212,5		225,8	-12																			
B1/14	max	-23	206,5																						
B1/14	max	-23	208,5																						
B1/14	max	-23	208																						
B1/14	max	-14	223																						
B1/14	max	-16	223																						
claris	max	-1	219	222,3																					
claris	max	-2,5	224																						
claris	max	-2	223																						
claris	max	-3	223																						
bwt	max	-1,5	219,5	219,5																					

Written by: Franco Uva R&D  
 Checked by:  
 Reviewed by:  
 Approved by:

CONFIDENTIALITY and WARNING NOTICE: this documents contain legally privileged or confidential information. Any dissemination, distribution and copyng of the contents of this document is strictly forbidden.

# MSDS & COSHH



## LAICA spa

DOCUMENT CODE	E0BAB04	EDITION NUMBER	01	DATE	08/11/2021
---------------	---------	----------------	----	------	------------

### 2.2 DESCALING AND PH TEST

		Test report	
DOCUMENT No.	Test_16	TEST METHOD	
DATE	22/09/2021	Internal Laica Lab.	
LOCATION	Internal Laica Lab.	Each filter cartridge is placed inside a tank, housed on a connection fitting, simulating the original unit.	
HARDNESS WATER	25±2°f	Each filter cartridge is connected to a piston pump with fixed capacity. The pump is controlled by a timer that sets the cycles. The cycles are regulated by: (1) activation pump ON (2) pump mode sleep. The challenge water (RO) is made with tap water, and hardness up to 20 °d (35 °F) ± 2 °d.	
CHALLENGE WATER	RO TANK	Hardness test is carried out with Nanocolor equipment	
TEMPERATURE CHALLENGE WATER RO	22±2°C	PH testing is performed with HANNA testers.	
HARDNESS CHALLENGE WATER	RO as shown	The system takes on average 200 cc/20 seconds every 12 minutes	
TEST METHOD	PISTON PUMP 200cc each 12min		

Lit	R zero						LAICA POWER BLUE										LAICA POWER BLUE											
	RO °d	RO °f	pH	Ca <sup>++</sup> mg/L	Mg <sup>++</sup> mg/L	Na <sup>+</sup> mg/L	°d	°f	pH	T (°C)	%	Ca <sup>++</sup> mg/L	Ca <sup>++</sup> %	Mg <sup>++</sup> mg/L	Mg <sup>++</sup> %	Na <sup>+</sup> mg/L	H <sub>2</sub> O ml	°d	°f	pH	T (°C)	%	Ca <sup>++</sup> mg/L	Ca <sup>++</sup> %	Mg <sup>++</sup> mg/L	Mg <sup>++</sup> %	Na <sup>+</sup> mg/L	H <sub>2</sub> O ml
0.4	22.5	40.3	6.38	101	25	1.2	0.0	0.0	6.24	23.6	100%	0	100%	0	100%	152	200	0.4	0.7	6.27	23.6	98%	0	100%	0	100%	159	200
1	22.5	40.3	6.38	101	25	1.2	1.8	3.2	6.30	21.4	92%	0	100%	0	100%	131	200	2.4	4.3	6.34	21.4	89%	0	100%	0	100%	134	200
2	22.5	40.3	6.38	101	25	1.2	2.2	4.0	6.24	22.6	90%	0	100%	0	100%	122	200	2.7	4.8	6.28	22.6	88%	0	100%	0	100%	119	200
3	22.5	40.3	6.38	101	25	1.2	2.1	3.7	6.16	22.6	91%	0	100%	0	100%	119	200	3.6	6.4	6.23	22.6	84%	0	100%	0	100%	112	200
5	22.5	40.3	6.38	101	25	1.2	3.6	6.4	6.08	23.8	84%	17	83%	5	80%	65.4	200	4.0	7.2	6.08	23.8	82%	20	80%	5	80%	67.1	200
7	22.5	40.3	6.38	101	25	1.2	4.3	7.7	6.18	22.0	81%	23	77%	5	80%	51.4	200	6.2	11.1	6.27	22.0	72%	31	69%	9	64%	44.2	200
10	22.5	40.3	6.38	101	25	1.2	7.0	12.5	6.18	23.4	69%	35	66%	12	52%	25.8	200	8.6	15.4	6.22	23.4	62%	38	63%	16	36%	20.7	200
12	21.8	39.0	6.48	97	28	1.1	6.3	11.3	6.20	22.1	71%	36	63%	7	75%	7.7	200	7.9	14.1	6.24	22.1	64%	40	59%	10	64%	4.6	200
15	21.8	39.0	6.48	97	28	1.1	8.5	15.2	6.30	23.1	61%	41	58%	11	61%	2.0	200	8.5	15.2	6.40	23.1	61%	43	56%	10	64%	2.4	200
20	21.8	39.0	6.48	97	28	1.1	10.3	18.4	6.56	23.8	53%	52	46%	14	50%	2.7	200	10.2	18.3	6.65	23.8	53%	52	44%	11	61%	2.6	200
25	21.2	37.9	6.47	102	28	2.1	9.2	16.5	6.19	23.4	57%	58	43%	14	50%	3.1	200	9.6	17.2	6.21	23.4	55%	57	44%	12	57%	2.5	200
30	21.2	37.9	6.56	102	28	2.1	10.1	18.1	6.39	24.2	52%	55	46%	16	43%	3.2	200	10.4	18.6	6.43	24.2	51%	56	45%	16	43%	3.1	200
40	21.8	39.0	6.53	112	35	2.1	14.2	25.4	6.28	24.3	35%	54	52%	29	17%	3.9	200	15.1	27.0	6.31	24.3	31%	61	46%	30	14%	4.1	200
50	21.0	37.6	6.51	92	31	3.1	13.7	24.5	6.89	23.5	35%	69	25%	25	19%	4.5	200	14.3	25.6	7.11	23.5	32%	68	26%	27	13%	4.2	200
60	21.5	38.5	6.63	114	37	3.6	15.4	27.5	6.58	21.5	28%	54	53%	34	8%	4.7	200	15.7	28.0	6.92	21.5	27%	60	47%	33	11%	4.0	200
70	21.4	38.3	6.87	110	34	2.1	18.5	33.1	6.44	22.3	14%	65	41%	30	12%	4.6	200	19.0	34.0	6.50	22.3	11%	68	38%	32	6%	4.4	200
80	21.2	37.9	7.29	129	36	3.9	17.8	31.9	6.74	22.6	16%	84	35%	35	3%	5.0	200	18.2	32.6	6.84	22.6	14%	92	29%	35	3%	4.8	200

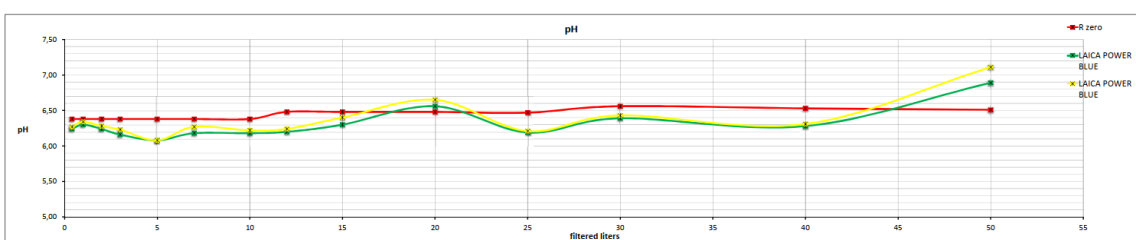
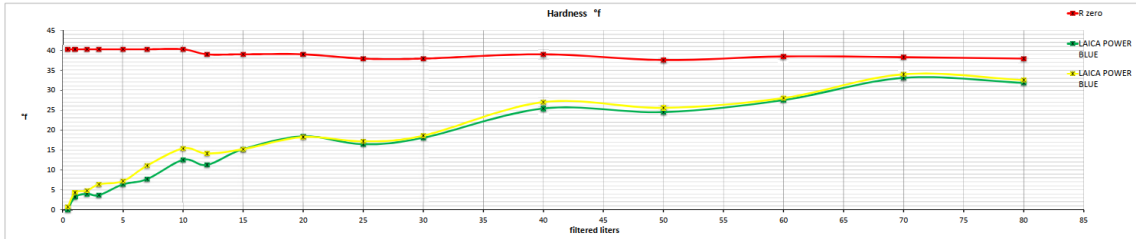
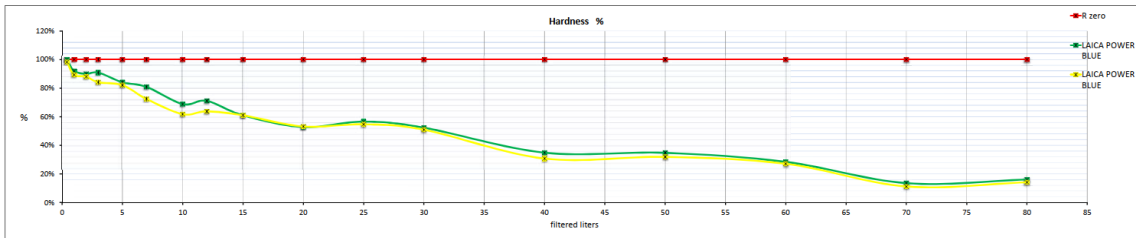
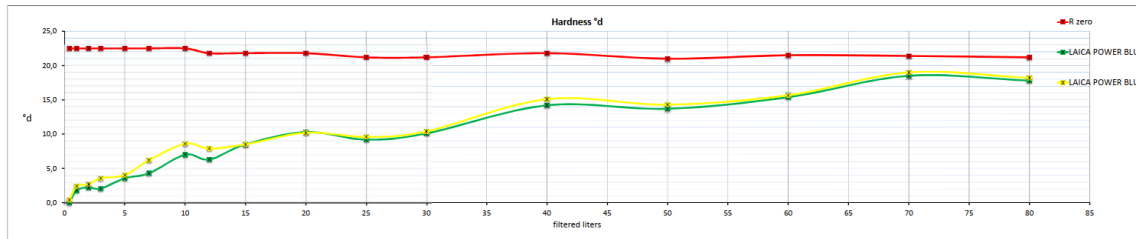

Written by: Franco Uva R&D  
 Checked by:  
 Reviewed by:  
 Approved by:

CONFIDENTIALITY and WARNING NOTICE: this documents contain legally privileged or confidential information. Any dissemination, distribution and copying of the contents of this document is strictly forbidden.





# MSDS & COSHH

 <h2 style="margin: 0;">LAICA spa</h2>					
DOCUMENT CODE	EOBAB04	EDITION NUMBER	01	DATE	08/11/2021



Rapporto di prova n°: **21RP04993** del 29/10/2021

Spett.le  
**LAICA S.p.A.**  
Viale del Lavoro, 10  
36048Bantano Montebelluna (VI)

**Dati di accettazione**

Metriche: **Acque di processo**  
 Trasporto: **Cliente**  
 Data arrivo: **26/10/2021** Ora arrivo: **12.32**  
 Data accettazione: **26/10/2021**



**Dati relativi al campione (C)**

Descrizione: **Acqua del 13/10/2021 - Litro: 1 - Lotto B5**

**Dati relativi al campionamento**

Campionamento a cura di: **Cliente**  
 Luogo: **Sede del Cliente**



CHIMICAMBIENTE SRL - Sede legale ed operativa: Via Lomellole da Vico, 2 - 36022 ESTE (PD)  
 Tel. 0429 80862 - CF PIVA - P.Ivan Reg. Imp. 0488982329 R.E.A. 01209 - ISD: 89020291  
 www.chimicambiente.com - e-mail: info@chimicambiente.com / per: chimicambiente@chimicambiente.com

Stampato in data: 29/10/2021

Pagina 1 di 2



Rapporto di prova n°: **21RP04993** del 29/10/2021

Documentazione - Specifiche

Documentazione - Specifiche	U.M.	Risultato	Limite	U.M.	Risultato	Limite	U.M.	Risultato	Limite	U.M.	Risultato	Limite	U.M.	Risultato	Limite	U.M.	Risultato	Limite	U.M.	Risultato	Limite	U.M.	Risultato	Limite
Decreto Min. 01/08/2013	mg/l	5,7	6,0	mg/l	1,4	1,5	mg/l	NO	1,0	mg/l	1,4	1,5	mg/l	5,3	6,0	mg/l	NO	1,0	mg/l	1,4	1,5	mg/l	5,3	6,0
Decreto Min. 01/08/2013	mg/l	5,7	6,0	mg/l	1,4	1,5	mg/l	NO	1,0	mg/l	1,4	1,5	mg/l	5,3	6,0	mg/l	NO	1,0	mg/l	1,4	1,5	mg/l	5,3	6,0
Decreto Min. 01/08/2013	mg/l	5,7	6,0	mg/l	1,4	1,5	mg/l	NO	1,0	mg/l	1,4	1,5	mg/l	5,3	6,0	mg/l	NO	1,0	mg/l	1,4	1,5	mg/l	5,3	6,0
Decreto Min. 01/08/2013	mg/l	5,7	6,0	mg/l	1,4	1,5	mg/l	NO	1,0	mg/l	1,4	1,5	mg/l	5,3	6,0	mg/l	NO	1,0	mg/l	1,4	1,5	mg/l	5,3	6,0
Decreto Min. 01/08/2013	mg/l	5,7	6,0	mg/l	1,4	1,5	mg/l	NO	1,0	mg/l	1,4	1,5	mg/l	5,3	6,0	mg/l	NO	1,0	mg/l	1,4	1,5	mg/l	5,3	6,0
Decreto Min. 01/08/2013	mg/l	5,7	6,0	mg/l	1,4	1,5	mg/l	NO	1,0	mg/l	1,4	1,5	mg/l	5,3	6,0	mg/l	NO	1,0	mg/l	1,4	1,5	mg/l	5,3	6,0
Decreto Min. 01/08/2013	mg/l	5,7	6,0	mg/l	1,4	1,5	mg/l	NO	1,0	mg/l	1,4	1,5	mg/l	5,3	6,0	mg/l	NO	1,0	mg/l	1,4	1,5	mg/l	5,3	6,0
Decreto Min. 01/08/2013	mg/l	5,7	6,0	mg/l	1,4	1,5	mg/l	NO	1,0	mg/l	1,4	1,5	mg/l	5,3	6,0	mg/l	NO	1,0	mg/l	1,4	1,5	mg/l	5,3	6,0
Decreto Min. 01/08/2013	mg/l	5,7	6,0	mg/l	1,4	1,5	mg/l	NO	1,0	mg/l	1,4	1,5	mg/l	5,3	6,0	mg/l	NO	1,0	mg/l	1,4	1,5	mg/l	5,3	6,0
Decreto Min. 01/08/2013	mg/l	5,7	6,0	mg/l	1,4	1,5	mg/l	NO	1,0	mg/l	1,4	1,5	mg/l	5,3	6,0	mg/l	NO	1,0	mg/l	1,4	1,5	mg/l	5,3	6,0
Decreto Min. 01/08/2013	mg/l	5,7	6,0	mg/l	1,4	1,5	mg/l	NO	1,0	mg/l	1,4	1,5	mg/l	5,3	6,0	mg/l	NO	1,0	mg/l	1,4	1,5	mg/l	5,3	6,0
Decreto Min. 01/08/2013	mg/l	5,7	6,0	mg/l	1,4	1,5	mg/l	NO	1,0	mg/l	1,4	1,5	mg/l	5,3	6,0	mg/l	NO	1,0	mg/l	1,4	1,5	mg/l	5,3	6,0
Decreto Min. 01/08/2013	mg/l	5,7	6,0	mg/l	1,4	1,5	mg/l	NO	1,0	mg/l	1,4	1,5	mg/l	5,3	6,0	mg/l	NO	1,0	mg/l	1,4	1,5	mg/l	5,3	6,0
Decreto Min. 01/08/2013	mg/l	5,7	6,0	mg/l	1,4	1,5	mg/l	NO	1,0	mg/l	1,4	1,5	mg/l	5,3	6,0	mg/l	NO	1,0	mg/l	1,4	1,5	mg/l	5,3	6,0
Decreto Min. 01/08/2013	mg/l	5,7	6,0	mg/l	1,4	1,5	mg/l	NO	1,0	mg/l	1,4	1,5	mg/l	5,3	6,0	mg/l	NO	1,0	mg/l	1,4	1,5	mg/l	5,3	6,0
Decreto Min. 01/08/2013	mg/l	5,7	6,0	mg/l	1,4	1,5	mg/l	NO	1,0	mg/l	1,4	1,5	mg/l	5,3	6,0	mg/l	NO	1,0	mg/l	1,4	1,5	mg/l	5,3	6,0
Decreto Min. 01/08/2013	mg/l	5,7	6,0	mg/l	1,4	1,5	mg/l	NO	1,0	mg/l	1,4	1,5	mg/l	5,3	6,0	mg/l	NO	1,0	mg/l	1,4	1,5	mg/l	5,3	6,0
Decreto Min. 01/08/2013	mg/l	5,7	6,0	mg/l	1,4	1,5	mg/l	NO	1,0	mg/l	1,4	1,5	mg/l	5,3	6,0	mg/l	NO	1,0	mg/l	1,4	1,5	mg/l	5,3	6,0
Decreto Min. 01/08/2013	mg/l	5,7	6,0	mg/l	1,4	1,5	mg/l	NO	1,0	mg/l	1,4	1,5	mg/l	5,3	6,0	mg/l	NO	1,0	mg/l	1,4	1,5	mg/l	5,3	6,0
Decreto Min. 01/08/2013	mg/l	5,7	6,0	mg/l	1,4	1,5	mg/l	NO	1,0	mg/l	1,4	1,5	mg/l	5,3	6,0	mg/l	NO	1,0	mg/l	1,4	1,5	mg/l	5,3	6,0
Decreto Min. 01/08/2013	mg/l	5,7	6,0	mg/l	1,4	1,5	mg/l	NO	1,0	mg/l	1,4	1,5	mg/l	5,3	6,0	mg/l	NO	1,0	mg/l	1,4	1,5	mg/l	5,3	6,0
Decreto Min. 01/08/2013	mg/l	5,7	6,0	mg/l	1,4	1,5	mg/l	NO	1,0	mg/l	1,4	1,5	mg/l	5,3	6,0	mg/l	NO	1,0	mg/l	1,4	1,5	mg/l	5,3	6,0
Decreto Min. 01/08/2013	mg/l	5,7	6,0	mg/l	1,4	1,5	mg/l	NO	1,0	mg/l	1,4	1,5	mg/l	5,3	6,0	mg/l	NO	1,0	mg/l	1,4	1,5	mg/l	5,3	6,0
Decreto Min. 01/08/2013	mg/l	5,7	6,0	mg/l	1,4	1,5	mg/l	NO	1,0	mg/l	1,4	1,5	mg/l	5,3	6,0	mg/l	NO	1,0	mg/l	1,4	1,5	mg/l	5,3	6,0
Decreto Min. 01/08/2013	mg/l	5,7	6,0	mg/l	1,4	1,5	mg/l	NO	1,0	mg/l	1,4	1,5	mg/l	5,3	6,0	mg/l	NO	1,0	mg/l	1,4	1,5	mg/l	5,3	6,0
Decreto Min. 01/08/2013	mg/l	5,7	6,0	mg/l	1,4	1,5	mg/l	NO	1,0	mg/l	1,4	1,5	mg/l	5,3	6,0	mg/l	NO	1,0	mg/l	1,4	1,5	mg/l	5,3	6,0
Decreto Min. 01/08/2013	mg/l	5,7	6,0	mg/l	1,4	1,5	mg/l	NO	1,0	mg/l	1,4	1,5	mg/l	5,3	6,0	mg/l	NO	1,0	mg/l	1,4	1,5	mg/l	5,3	6,0
Decreto Min. 01/08/2013	mg/l	5,7	6,0	mg/l	1,4	1,5	mg/l	NO	1,0	mg/l	1,4	1,5	mg/l	5,3	6,0	mg/l	NO	1,0	mg/l	1,4	1,5	mg/l	5,3	6,0
Decreto Min. 01/08/2013	mg/l	5,7	6,0	mg/l	1,4	1,5	mg/l	NO	1,0	mg/l	1,4	1,5	mg/l	5,3	6,0	mg/l	NO	1,0	mg/l	1,4	1,5	mg/l	5,3	6,0
Decreto Min. 01/08/2013	mg/l	5,7	6,0	mg/l	1,4	1,5	mg/l	NO	1,0	mg/l	1,4	1,5	mg/l	5,3	6,0	mg/l	NO	1,0	mg/l	1,4	1,5	mg/l	5,3	6,0
Decreto Min. 01/08/2013	mg/l	5,7	6,0	mg/l	1,4	1,5	mg/l	NO	1,0	mg/l	1,4	1,5	mg/l	5,3	6,0	mg/l	NO	1,0	mg/l	1,4	1,5	mg/l	5,3	6,0
Decreto Min. 01/08/2013	mg/l	5,7	6,0	mg/l	1,4	1,5	mg/l	NO	1,0	mg/l	1,4	1,5	mg/l	5,3	6,0	mg/l	NO	1,0	mg/l	1,4	1,5	mg/l	5,3	6,0
Decreto Min. 01/08/2013	mg/l	5,7	6,0	mg/l	1,4	1,5	mg/l	NO	1,0	mg/l	1,4	1,5	mg/l	5,3	6,0	mg/l	NO	1,0	mg/l	1,4	1,5	mg/l	5,3	6,0
Decreto Min. 01/08/2013	mg/l	5,7	6,0	mg/l	1,4	1,5	mg/l	NO	1,0	mg/l	1,4	1,5	mg/l	5,3	6,0	mg/l	NO	1,0	mg/l	1,4	1,5	mg/l	5,3	6,0
Decreto Min. 01/08/2013	mg/l	5,7	6,0	mg/l	1,4	1,5	mg/l	NO	1,0	mg/l	1,4	1,5	mg/l	5,3	6,0	mg/l	NO	1,0	mg/l	1,4	1,5	mg/l	5,3	6,0
Decreto Min. 01/08/2013	mg/l	5,7	6,0	mg/l	1,4	1,5	mg/l	NO	1,0	mg/l	1,4	1,5	mg/l	5,3	6,0	mg/l	NO	1,0	mg/l	1,4	1,5	mg/l	5,3	6,0
Decreto Min. 01/08/2013	mg/l	5,7	6,0	mg/l	1,4	1,5	mg/l	NO	1,0	mg/l	1,4	1,5	mg/l	5,3	6,0	mg/l	NO	1,0	mg/l	1,4	1,5	mg/l	5,3	6,0
Decreto Min. 01/08/2013	mg/l	5,7	6,0	mg/l	1,4	1,5	mg/l	NO	1,0	mg/l	1,4	1,5	mg/l	5,3	6,0	mg/l	NO	1,0	mg/l	1,4	1,5	mg/l	5,3	6,0
Decreto Min. 01/08/2013	mg/l	5,7	6,0	mg/l	1,4	1,5	mg/l	NO	1,0	mg/l	1,4	1,5	mg/l	5,3	6,0	mg/l	NO	1,0	mg/l	1,4	1,5	mg/l	5,3	6,0
Decreto Min. 01/08/2013	mg/l	5,7	6,0	mg/l	1,4	1,5	mg/l	NO	1,0	mg/l	1,4	1,5	mg/l	5,3	6,0	mg/l	NO	1,0	mg/l	1,4	1,5	mg/l	5,3	6,0
Decreto Min. 01/08/2013	mg/l	5,7	6,0	mg/l	1,4	1,5	mg/l	NO	1,0	mg/l	1,4	1,5	mg/l	5,3	6,0	mg/l	NO	1,0	mg/l	1,4	1,5	mg/l	5,3	6,0
Decreto Min. 01/08/2013	mg/l	5,7	6,0	mg/l	1,4	1,5	mg/l	NO	1,0	mg/l	1,4	1,5	mg/l	5,3	6,0	mg/l	NO	1,0	mg/l	1,4	1,5	mg/l	5,3	6,0
Decreto Min. 01/08/2013	mg/l	5,7	6,0	mg/l	1,4	1,5	mg/l	NO	1,0	mg/l	1,4	1,5	mg/l	5,3	6,0	mg/l	NO	1,0	mg/l	1,4	1,5	mg/l	5,3	6,0
Decreto Min. 01/08/2013	mg/l	5,7	6,0	mg/l	1,4	1,5	mg/l	NO	1,0	mg/l	1,4	1,5	mg/l	5,3	6,0	mg/l	NO	1,0	mg/l	1,4	1,5	mg/l	5,3	6,0
Decreto Min. 01/08/2013	mg/l	5,7	6,0	mg/l	1,4	1,5	mg/l	NO	1,0	mg/l	1,4	1,5	mg/l	5,3	6,0	mg/l	NO	1,0	mg/l	1,4	1,5	mg/l	5,3	6,0
Decreto Min. 01/08/2013	mg/l	5,7	6,0	mg/l	1,4	1,5	mg/l	NO	1,0	mg/l	1,4	1,5	mg/l	5,3	6,0	mg/l	NO	1,0	mg/l	1,4	1,5	mg/l	5,3	6,0
Decreto Min. 01/08/2013	mg/l	5,7	6,0	mg/l	1,4	1,5																		









# MSDS & COSHH

 <h2 style="margin: 0;">LAICA spa</h2>					
DOCUMENT CODE	EOBAB04	EDITION NUMBER	01	DATE	08/11/2021



Rapporto di prova n°: 21RP04998 del 29/10/2021

Società  
**LAICA s.p.a.**  
Viale del Lavoro, 10  
38048Bantorno, Messano (VI)



**Dati di accettazione**  
Materie: Acque di processo  
Trasporto: Cliente  
Data arrivo: 26/10/2021 Ora arrivo: 12.52  
Data accettazione: 26/10/2021

**Dati relativi al campione (C)**

Descrizione: Acque del 21/10/2021 - Litro: 75 - Lotto: AA

**Dati relativi al campionamento**

Campionamento a cura di: Clienti  
Luogo: Sede del Cliente



COSMICAMBIENTE SRL - Sede legale ed operativa: Via Lavinio da Vinc. 2 - 38042 BZ (BZ)  
Tel. 0475 80002 - CF P.V.A. n° 04758001239 R.E.A. 01208 - CH 89020021  
www.chimicambiente.com - e-mail: info@chimicambiente.com - pec: chimicambiente@pec.it

Stampato in data: 29/10/2021

Pagina 1 di 2



Rapporto di prova n°: 21RP04998 del 29/10/2021

Descrizione - Specifiche

Descrizione	U.M.	Risultato	Limite	Limite	Passa/Non Passa
APNT CN6 RSA 2010 B Mar 28 2020	mg/CaCO3	334	61	61	OK
APNT CN6 RSA 2010 B Mar 28 2020	mg/l	2.0	6.1	6.1	OK
APNT CN6 RSA 2010 B Mar 28 2020	mg/l	NG	6.1	6.1	OK
APNT CN6 RSA 2010 B Mar 28 2020	mg/l	2.0	6.1	6.1	OK
<b>21RP0499801 Durezza permanente</b>					
Descrizione - Specifiche	U.M.	Risultato	Limite	Limite	Passa/Non Passa
APNT CN6 RSA 2010 B Mar 28 2020	mg/CaCO3	269	61	61	OK

Questo è un documento riservato. È vietata espressamente la ristampa o l'uso non autorizzato senza permesso scritto dal laboratorio. Il presente rapporto di prova è valido solo per il campione specificato e non deve essere considerato un riferimento per altri campioni. Il presente rapporto di prova è valido solo per il campione specificato e non deve essere considerato un riferimento per altri campioni. Il presente rapporto di prova è valido solo per il campione specificato e non deve essere considerato un riferimento per altri campioni.

**SE NON DIVERSAMENTE SPECIFICATO** i risultati del presente rapporto di prova non risultano correlati per i valori di recupero (R) in quanto i valori del recupero (R) nella tabella indicata nel metodo di prova. Le sottrazioni sono calcolate mediante il calcolo del lower bound (L.B.). Il metodo di campionamento viene identificato nel presente rapporto di prova con il numero di campionamento per campione (C) e il numero di lotto (L). Il numero di campionamento per campione (C) è indicato nel presente rapporto di prova.

Direttore Tecnico  
Dr. Giovanni Milentona  
Chimico  
Ordine Interprov. Chimici del Veneto - Padova n° 910 SEZ. A

File Rapporto di Prova



COSMICAMBIENTE SRL - Sede legale ed operativa: Via Lavinio da Vinc. 2 - 38042 BZ (BZ)  
Tel. 0475 80002 - CF P.V.A. n° 04758001239 R.E.A. 01208 - CH 89020021  
www.chimicambiente.com - e-mail: info@chimicambiente.com - pec: chimicambiente@pec.it

Stampato in data: 29/10/2021

Pagina 2 di 2

Written by: Franco Uva R&D  
Checked by:  
Reviewed by:  
Approved by:

CONFIDENTIALITY and WARNING NOTICE: this documents contain legally privileged or confidential information. Any dissemination, distribution and copying of the contents of this document is strictly forbidden.



# MSDS & COSHH

		LAICA spa			
DOCUMENT CODE	E0BAB04	EDITION NUMBER	01	DATE	08/11/2021

## 3. COMPLIANCES



### DECLARATION OF COMPLIANCE

Laica S.p.A.

Viale Del Lavoro, 10- Fraz. Ponte - 36048 Barbarano Mossano – Vicenza – Italia

Declares under its sole responsibility, that:

#### Category

Filter cartridges POWER WHITE/POWER BLUE/POWER AROMA manufactured by LAICA, all RAW MATERIALS (plastics for injections, carbons and resins for media) and components employed for their mass production comply with below directives and regulations:

- European Regulation 1935/2004/EU relative to materials and articles intended to come into contact with food,
- European Regulation 10/2011/EU relative to plastic materials and articles intended to come into contact with food,
- European Regulation 2023/2006/EU on good manufacturing practice for materials and articles intended to come into contact with food,

Barbarano Mossano, 06/07/2021

Riccardo Dolcetta Capuzzo

Nicolò Zanuso



LAICA S.p.A. - Società con socio unico soggetta all'attività di direzione e coordinamento di Strix Group Pic.  
Viale del Lavoro, 10 – Fraz. Ponte – 36048 Barbarano Mossano (VI) – Italy  
Tel. +39 0444 795314 – 795321 – Fax +39 0444 795324 – e-mail: [info@laica.com](mailto:info@laica.com)  
Reg. Impr. e P.IVA 00288500242 – Capitale Sociale €1.000.000,00 i.v

Written by: Franco Uva R&D  
Checked by:  
Reviewed by:  
Approved by:

CONFIDENTIALITY and WARNING NOTICE: this documents contain legally privileged or confidential information. Any dissemination, distribution and copyng of the contents of this document is strictly forbidden

# MSDS & COSHH

	LAICA spa				
DOCUMENT CODE	EOBAB04	EDITION NUMBER	01	DATE	08/11/2021

## 4. PACKAGING

FLOW PACK	
DIE CUT DRAWING	
FILM CODE	
MATERIALS	PET12+PE35
DIMENSION OF FLOW PACK	240x80x45
WEIGHT	107 +/- 10%

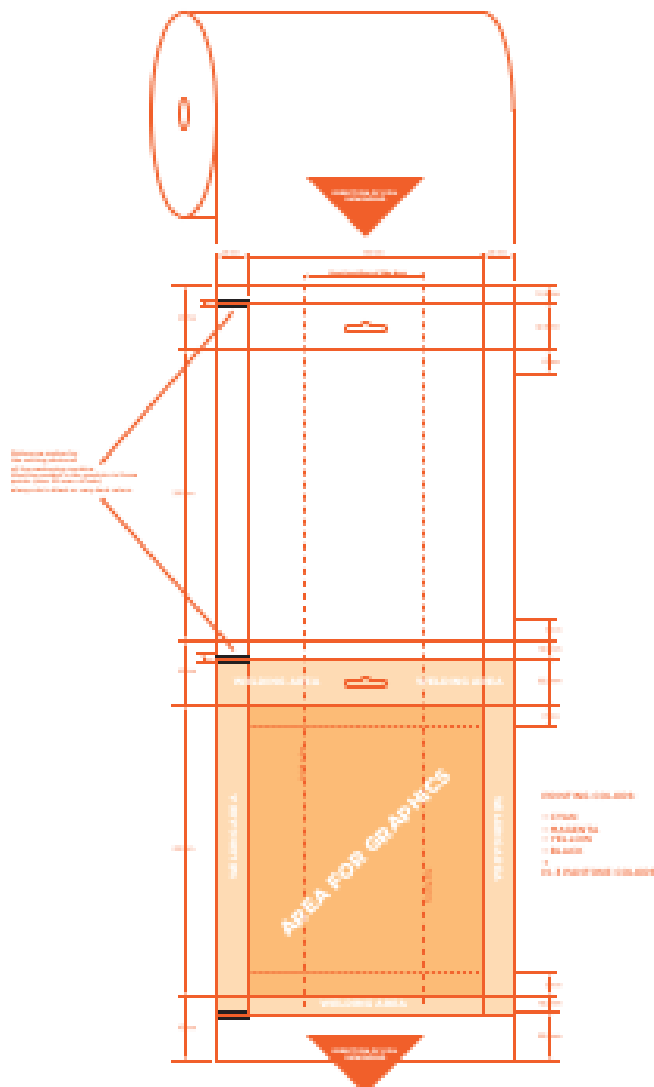

Written by: Franco Uva R&D  
Checked by:  
Reviewed by:  
Approved by:

CONFIDENTIALITY and WARNING NOTICE: this documents contain legally privileged or confidential information. Any dissemination, distribution and copyng of the contents of this document is strictly forbidden.

# MSDS & COSHH

 LAICA spa					
DOCUMENT CODE	E0BAB04	EDITION NUMBER	01	DATE	08/11/2021

GIFT BOX
NO

MASTER CARTON	
TIPE CODE OF MATER CARTON	
DIMENSION	390x390x200
N° OF PIECES PER MASTER CARTON	64
GROSS WEIGHT	
NUMBERS OF CARTON PER PALLET	54
NUMBERS OF FILTER PER PALLET	3456

## 5. TRACEABILITY

### 5.1 BATCH IDENTIFICATION

HOT PRINTED IN THE TOP OF THE FILTER CASE - PRINTED IN FLOW PACK - PRINTED IN MASTER CARTON LABEL

	
CODE: <b>E0BAB04</b>	BATCH: <b>DA034</b>
MODEL: POWER BLUE FILTER	
QTY.: 64 PCS	MEAS*: 38x38x18
BOX: 1 PCS	N.W.: Kg 6,4
	G.W.: Kg 6,8

### 5.2 UNIVOQUE CODE

**Code: E0BAB04**  
**Lot nr : DA034**  
**Caffitaly**  
**Serial Number:**  
**532114145809**

FILTER CODE						
BATCH NUMBER						
CAFFITALY						
SERIAL NUMBER						
MINUTES YEAR HOUR DAY SEC MONTH	53	21	14	14	58	09
	14:53:58	YEAR 2021	14:53:58	DAY 14	14:53:58	SEPTEMBER

Written by: Franco Uva R&D Checked by: Reviewed by: Approved by:	CONFIDENTIALITY and WARNING NOTICE: this documents contain legally privileged or confidential information. Any dissemination, distribution and copyng of the contents of this document is strictly forbidden.
---	---

# MSDS & COSHH

 Strix	LAICA spa				
DOCUMENT CODE	EOBAB04	EDITION NUMBER	01	DATE	08/11/2021

## 6. INSTRUCTION MANUALS

TBD

Written by: Franco Uva R&D  
Checked by:  
Reviewed by:  
Approved by:

CONFIDENTIALITY and WARNING NOTICE: this documents contain legally privileged or confidential information. Any dissemination, distribution and copyng of the contents of this document is strictly forbidden.

# MSDS & COSHH

	Costa Coffee Approved Sanitiser Policy	Document Reference	1.1.13
		Document Owner	Zoe Lambert
		Date Approved	20/09/2024
		Version Number	2
		Approved By	Louise Hickmott

Audience	Area
Global	TECHNICAL SUPPLY CHAIN
Intended Party	Platform
Costa (Including Global Innovation); Coca-Cola Bottler	Costa Self Served

## Costa Coffee Approved Sanitiser Policy

**Purpose:** To support the consistent delivery of high quality and safe vended beverages to consumers.

**Responsibility:** The Food Business Operator responsible for the vended beverages within the market must use Costa approved sanitisers for the manual cleaning of all Costa Express machines.

**Requirements:** The manual cleaning process must follow the cleaning frequency and cleaning steps as described in the relevant Machine Operator Manual. Dilution and contact time must be adhered to as per the specific sanitiser instructions.

The following list of sanitisers are approved for use only for use with Costa Express equipment:

Ecolab DrySan Oxy wipes
Holchem M2 spray
Ecolab Aseptopol 76 spray/aerosol
Diversey Suma Bac D10 spray
Cleenol EV3 spray
Diversey Oxivir
Selgeine Extreme T500 spray
Ecolab Oasis 146 Multi Quat spray (US use only)
Cif Professional (pro formula) spray
Ecolab Sink & Surface Cleaner Sanitiser
Ecolab Kay 5 sanitizer tablets

Sanytol All purpose
Greenspeed Lacto Des spray
Dettol All purpose cleaner
Dettol Disinfection Hygiene Cleaner
Diversey Suma QuickDes D4.12 spray
Ecolab Sirafan Speed spray
Ecolab P3 Alcodes spray
Lion Hygiene (Japan) High Alcohol
Astonish Antibacterial Spray
Dettol Multi-purpose cleaner
CiF Multi-purpose spray

To be approved for use, the sanitisers must pass Costa validation test protocols. To request validation, a formal change request must be raised via the Costa X Technical Manager and approved by the relevant change forum process.

REASON FOR CHANGE, CHANGES SINCE LAST VERSION
Updated to include removal of discontinued sanitiser & addition of US sanitiser

# Version control

---

Version	Date	Author	Changes
1.1	18.09.25	S.C.B	<ul style="list-style-type: none"><li>Added updated System Descaler info p2-10.</li></ul>
1.0	17.06.2025	S.C.B	<ul style="list-style-type: none"><li>Seperated out MSDS &amp; COSHH from the Operator Manual.</li></ul>



# Podio X1

MSDS and COSHH

